

# Section 1: Forces and motion

[[toc]]

## (a) Units

**1.1 use the following units: kilogram (kg), metre (m), metre/second (m/s), metre/second<sup>2</sup> (m/s<sup>2</sup>), newton (N), second (s), newton per kilogram (N/kg), kilogram metre/second (kg m/s).**

- Unit of mass=Kilogram (kg)
- Unit of distance=Metre (m)
- Unit of speed or velocity= Metre per second (m/s)
- Unit of acceleration= metre per second<sup>2</sup> (m/s<sup>2</sup>)
- Unit of Force= Newton(N)
- Unit of Time= Second(s)
- Unit of gravitational acceleration= Newton per kilogram(N/kg)
- Unit of Momentum= kilogram metre per second (kg m/s)

## (b) Movement and Position

**1.2 plot and interpret distance-time graphs**

**Distance** = The change of position of an object is called distance. The diagram shows an example:



Figure 1 shows an object changes its position from A to B. So the distance travelled by the object is AB.

**Displacement** = The change of position of an object in a particular direction is called displacement.

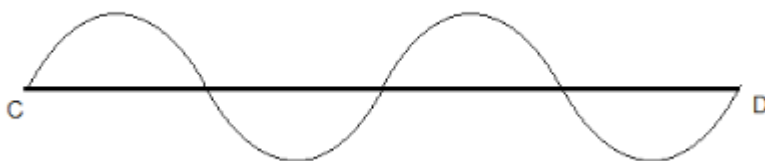
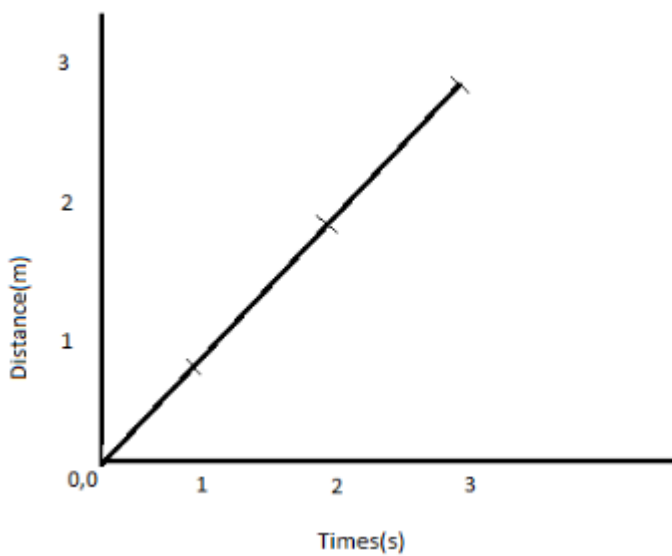

Figure 2 shows another object changes its position from C to D through curved path but the displacement will be straight distance from C to D.



### Distance-time graph

A distance-time graph represents the speed or velocity of any object. In this graph the object is moving at 1 m per second. It is in a constant speed. In a distance-time graph, distance should go to the Y-axis while time should go over the X-axis.

$Speed = gradient = distance/time = 3m/3s = 1m/s$

Few points that should be noted:

1. In a displacement - time graph or distance- time graph, the average velocity is found by the ratio  $\Delta s/\Delta t$  where  $\Delta s$  = change in displacement/distance and  $\Delta t$ =time interval
2. A positive gradient of the displacement-time graph indicates that the car is moving in the same direction as the displacement.
3. A negative gradient of the displacement-time graph indicates that the car is moving in the opposite direction to the displacement.
4. A zero gradient of the displacement-time curve shows that the car is stationary.

Some explanation of motion from graph:

Zero displacement	Constant displacement

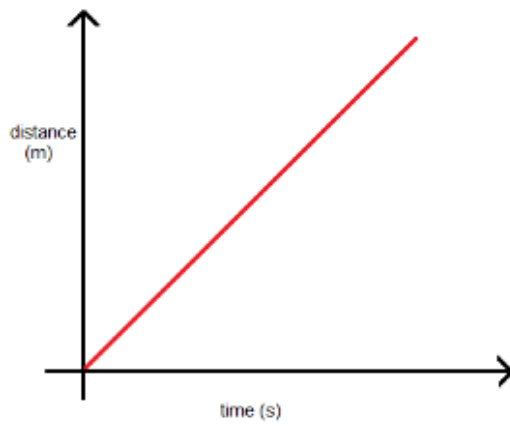
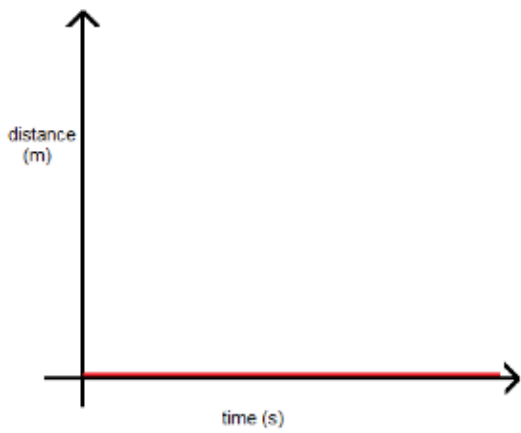

**Not moving**

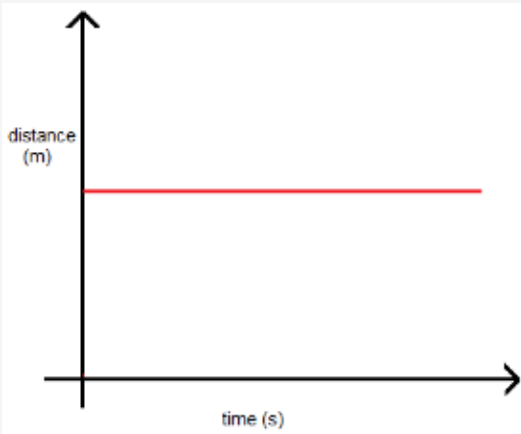

**Acceleration**

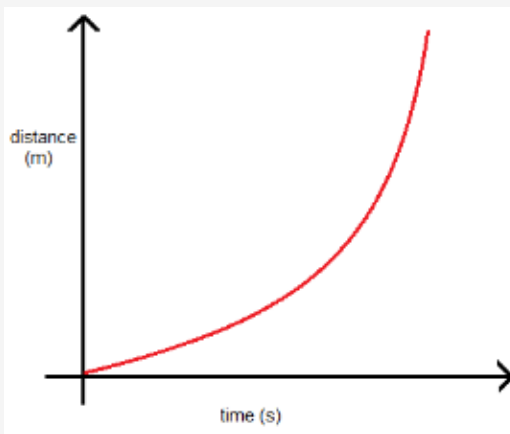

**Deceleration**

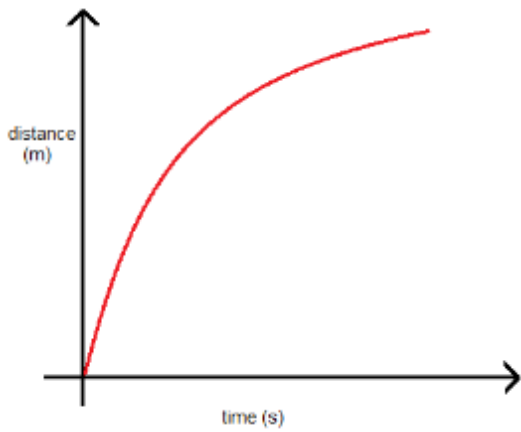

**1.3 know and use the relationship between average speed, distance moved and time:**

**average speed = distance moved /time taken**

Speed: Speed is defined as the rate of change of distance. In other words, speed is the distance moved per unit time. It tells us how fast or slow an object is moving.

Most objects or bodies do not move at constant speed. For example, the MRT train starts from rest at a station, moves faster and faster until it reaches a constant speed and then slows down to a stop at the next station. It is therefore more useful to define average speed rather than the actual speed.

Average speed: Average speed is the total distance moved divided by total time taken. If you see the graph in 1.2 it had an average speed of 1 m/s. This is the relation between speed and distance,time. Distance and time has no relation individually. They are both different types of values.

Instantaneous speed: The speed of an object at a particular moment is called instantaneous speed. It is measured by taking ratio of distance travelled by shortest possible time.

Difference between speed and velocity:

Speed	Velocity
i. The rate of distance travelled is speed.	i. The rate of displacement travelled is velocity.
ii. Speed can be in any direction.	ii. Velocity is speed in particular direction.
iii. Speed is a scalar quantity.	iii. Velocity is a vector quantity.

**1.4 describe experiments to investigate the motion of everyday objects such as toy cars or tennis balls**

::: details Experiment: Measuring speed using click and stopwatch

Suppose you want to find the speed of cars driving down your road. You may have seen the police using speed guns to check that drivers are keeping to the speed limit. Speed guns use microprocessors to produce an instant reading of the speed of a moving vehicle, but you can conduct a very simple experiment to measure car speed.

Measure the distance between two points along a straight section of road with a tape measure or “click” wheel. Use a stopwatch to measure the time taken for a car to travel the measured distance.

Use the speed, distance and time equation to work out the speed of the car.

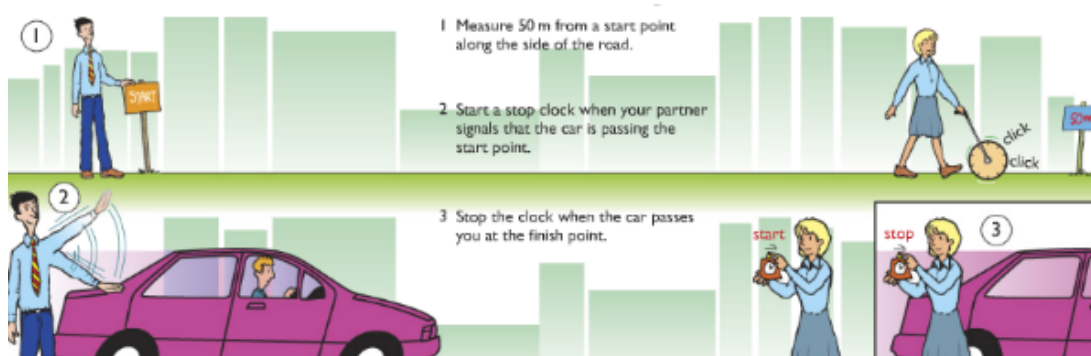

∴

∴ details Experiment: Measuring speed using light gate method

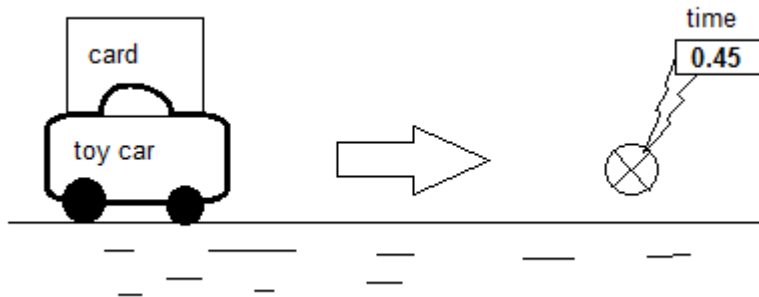

1. Attach a card of measured length centrally to the top of the toy car.
2. Air track ensures a frictionless way for the toy car.
3. A gentle push can move the toy car at a steady speed.
4. Arrange for the card to block a light gates beam as it passes through it.
5. Electronic timer measures how long the card takes to pass through the beam.
6. Now calculate the toy car's average velocity as it passes the light gate by:

$$v = \text{length of the card} / \text{interuption time}$$

∴

∴ details Experiment: Measuring speed using ticker-time method

TODO

∴

∴ details Experiment: Video (sequence) method - Measuring the velocity of a tennis ball.

A tennis ball is let to move on a track at a steady speed. During the ball moves, video the ball moving along in front of calibrated scale (a scale where there is marking in length) attached to the slope.

Play the video back to get the snap shots taken at a time. Measure how far the ball advances between snaps from the scale. The video camera can take 25 snaps each second. So the time between each snap is 0.04 second.

Now calculate the balls average velocity between snaps using the following equation:

$$\text{Velocity} = \text{distance moved between snaps} \div 0.04 \quad \therefore$$

∴ details Experiment: To find out Average Speed of Toy car or trolley

**Apparatus:** Toy car or tennis ball, meter rule, slotted masses, stopwatch, thread.

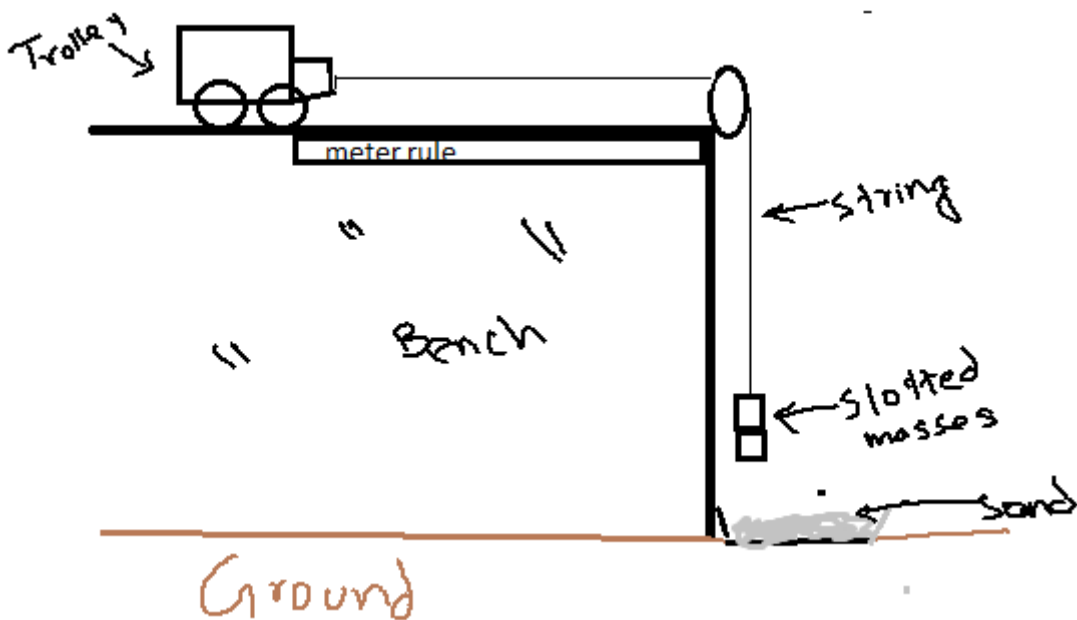

**Procedure:**

1. Put toy car on bench and attach pulley to the corner of the bench as shown in figure.
2. Attach one end of the thread with toy car and other end with slotted masses while hanging them over pulley.
3. Keep toy car & pulley one meter apart with meter rule.
4. Hold the toy with hand so that it remains there immovable.
5. Time stop watch when you let toy to move a meter distance.
6. Repeat this & record reading for different distances in the following chart.

S. No.	Distance (m)	Time (s)			
		1	2	3	Mean
1	0.2				
2	0.4				
3	0.6				
4	0.8				
5	1.0				

7. Draw graph to find out average speed, which can be found by finding the gradient of the graph.

**Precautions:**

1. Do not hang heavier masses as this may break the thread.
2. Wear shoes as to avoid injury to foot in case of broken thread and fall of mass.
3. Put something soft under the hanging mass, like tray filled with sand.

**Sources of error:**

1. Reaction time
2. Ruler may not be straight
3. Parallax error
4. Friction in the bench.

**Ways to improve:**

1. Bench should be very polished friction.
2. Tyres of the toy should not be very rough.
3. Use light-gates instead of the stopwatch and connect light-gates to datalogger and then to computer, to get more accurate results.

:::

::: details Experiment: Measuring acceleration using light gate method

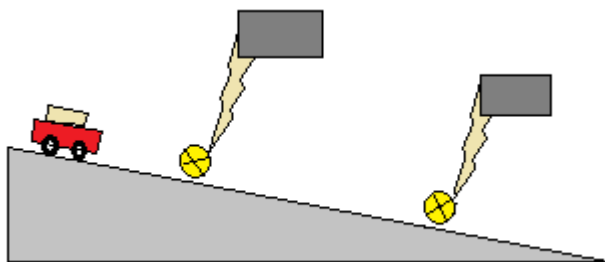

- A card is mounted on the top of a trolley. The length of the card is measured.
- One light is set at the top of the track and the second one is at the end of the track.
- The trolley is given a gentle push to move through the track.
- When the trolley passes through the first light gate the electronic timer measures the  $t_1$  to cross the length of the card.
- So the velocity at the position of first light gate is measured by velocity.
  - $V_1 = \text{length of the first card} \div t_1$
- During passing the second light gate, if the time measured by electronic timer is  $t_2$  then the velocity can be measured by:
  - $V_2 = \text{length of the second card} \div t_2$
- The time  $t_3$  is measured for the trolley to travel from first light gate to the second light gate by using a stopwatch.
- Now acceleration is =  $\text{velocity difference} \div t_3$

$$= \frac{(\text{length of first card} / t_2) - (\text{length of second card} / t_1)}{t_3}$$

:::

::: details Experiment: Measuring acceleration using Video (sequence) method

TODO

:::

::: details Experiment: Measuring acceleration using Modern Version of Galileo's experiment

Apparatus -

- Light gate
- Interrupter
- Air pumper
- Air track
- Data logger or electronic timer

Diagram -

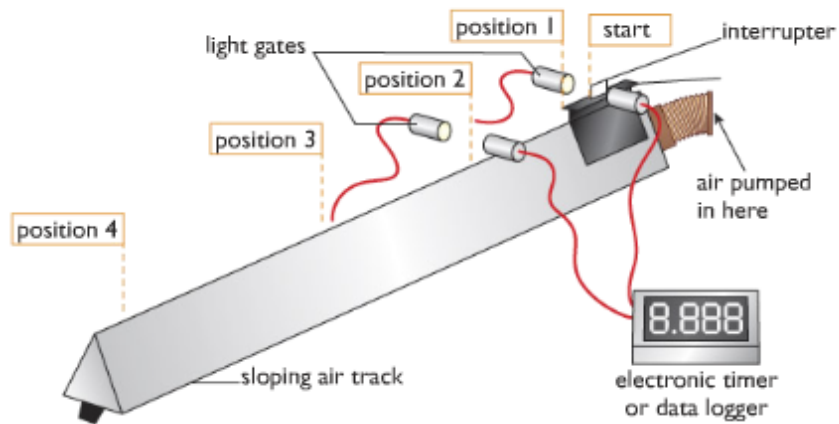

Working Procedure - We can measure the acceleration by conducting an experiment using an air-track which can be referred as the modern-version of Galileo experiment.

From the diagram show the investigation where we can see that the air-track reduces friction because the glider rides on a cushion of air that is pumped continuously through holes along the air track. As the glider accelerates down the sloping track the white card mounted on it breaks a light beam, and the time the glider takes to pass is measured electronically. If the length of the card is measured, and this is entered into the spreadsheet, the velocity of the glider can be calculated by the spreadsheet programme using  $v = d/t$ .

Observation - Here from the above procedure it is observed that the distance travelled in equal intervals is increased and that the rate of increase of speed is steady or uniform i.e. it is uniform acceleration.

Table and Graph



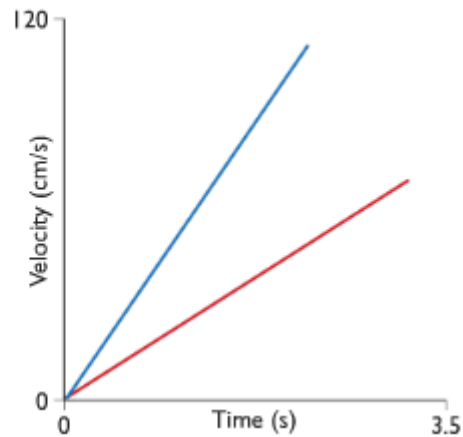

Airtrack at 1.5°		Airtrack at 3.0°	
Time (s)	Av Vel. (cm/s)	Time (s)	Av Vel. (cm/s)
0.00	0.0	0.00	0.0
0.45	11.1	0.32	15.9
1.35	33.3	0.95	47.6
2.25	55.6	1.56	79.4
3.15	77.8	2.21	111.1

### Conclusion

The gradient of a velocity-time graph gives the acceleration

...

... details Experiment: Measuring acceleration using double light gate.

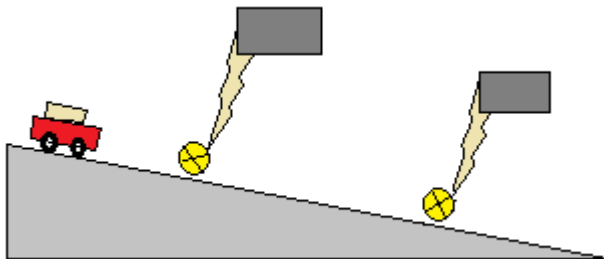

1. A card is mounted on the top of a trolley.
2. The length of the card is measured.
3. One light gate is at the top of the track and another light gate is at the end of the track.
4. The trolley is given a gentle push to move through the track.
5. When the trolley passes through the first light gate, the electronic timer measure the time ( $t_1$ ) to cross the length of the cord.
6. So the velocity at the position of first light gate is measured by:
  - velocity,  $v_1 = \text{length of the cord} / t_1$
7. The time,  $t_2$  is measured for the trolley to travel from first light gate to 2<sup>nd</sup> light gate by using a stopwatch.

8. Now, acceleration = velocity difference /  $t_3$

$$= \frac{(\text{length of card} / t_2) - (\text{length of card} / t_1)}{t_3}$$

:::

::: details Experiment: Measuring acceleration using ticker tape.

**Apparatus:** Ticker timer and tape, a.c. power supply, trolley, runway

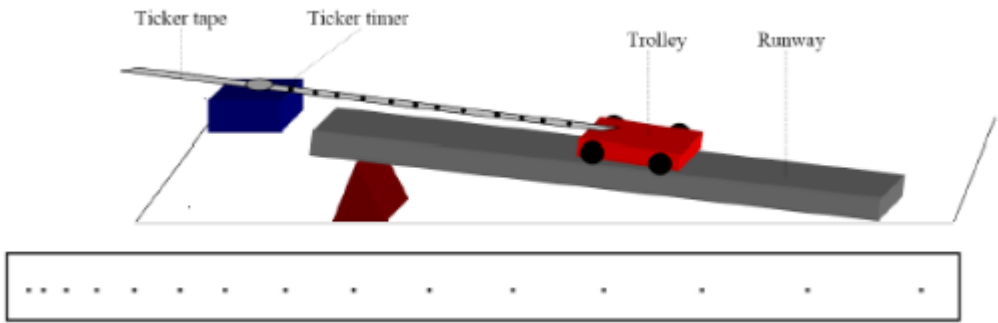

**Procedure:**

1. Set up the apparatus as in the diagram.
2. Connect the ticker timer to a suitable low-voltage power supply.
3. Allow the trolley to roll down the runway.
4. The trolley is accelerating as the distance between the spots is increasing.
5. The time interval between two adjacent dots is 0.02 s, assuming the ticker timer marks fifty dots per second.
6. Mark out five adjacent spaces near the beginning of the tape. Measure the length  $s_1$ .
7. The time  $t_1$  is  $5 \times 0.02 = 0.1$  s.
8. We can assume that the trolley was travelling at constant velocity for a small time interval.

Thus initial velocity  $u = \text{distance}/\text{time} = s_1/t_1$

1. Similarly mark out five adjacent spaces near the end of the tape and find the final velocity  $v$ .
2. Measure the distance  $s$  in metres from the centre point of  $u$  to the centre point of  $v$ .
3. The acceleration is found using the formula:  $v^2 = u^2 + 2as$  or  $a = (v^2 - u^2) / 2s$
4. By changing the tilt of the runway different values of acceleration are obtained. Repeat a number of times.
5. Tabulate results as shown.

$s_1$ (m)	$t_1$ (s)	$u$ ( $\text{m s}^{-1}$ )	$s_2$ (m)	$t_2$ (s)	$v$ ( $\text{m s}^{-1}$ )	$s$ (m)	$a$ ( $\text{m s}^{-2}$ )

:::

**1.5 know and use the relationship between acceleration, velocity and time:**

Acceleration is the rate at which objects change their velocity. The rate of decrease of velocity is called deceleration. It is just a negative acceleration. It is defined as follows:

*Acceleration = change in velocity / time taken*

or

*Acceleration = (final velocity - initial velocity) / time taken*

This is written as an equation:

$$a = (v - u) / t$$

where a=acceleration, v=final velocity, u=initial velocity and t=time

### 1.6 plot and interpret velocity-time graphs

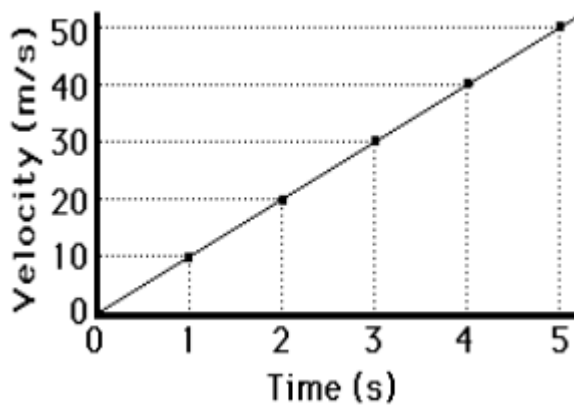

Velocity-time graphs represent the acceleration of any object. Velocity(m/s) is in the Y-axis while Time is the X-axis.

Some common velocity-time graphs:

**(i) Object at rest**

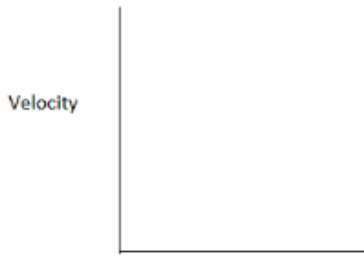

**(ii) Object moving at constant speed**



**(iii) Constant accelerations**

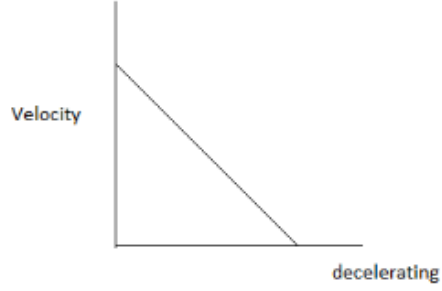
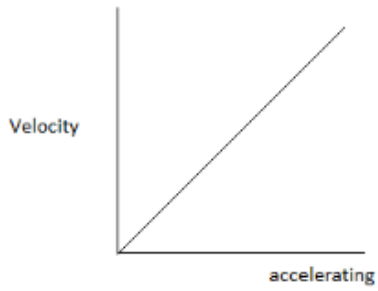

**(iv) Varying accelerations**

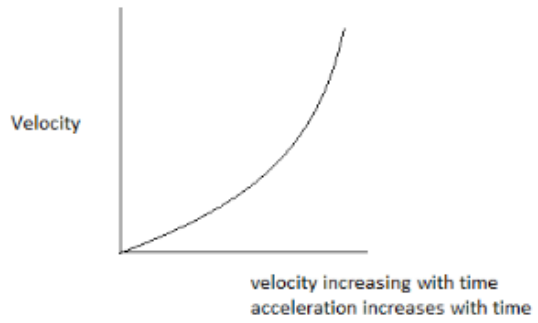
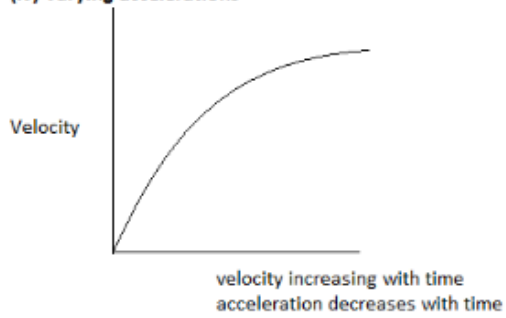

**1.7 determine acceleration from the gradient of a velocity-time graph**

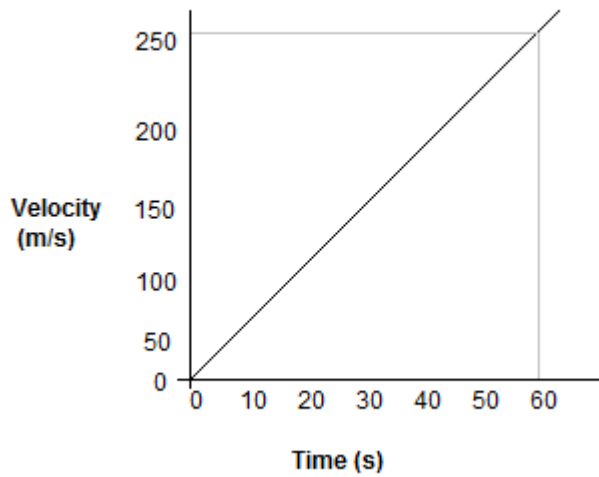

Acceleration = gradient  
 $= (y_2 - y_1) / (x_2 - x_1)$   
 $= (200 - 0) / (50 - 0)$   
 $= 4 \text{ meter per second squared}$

**1.8 determine the distance travelled from the area between a velocity-time graph and the time axis.**

Distance can be determined by finding the area under a velocity-time graph as shown below:

#

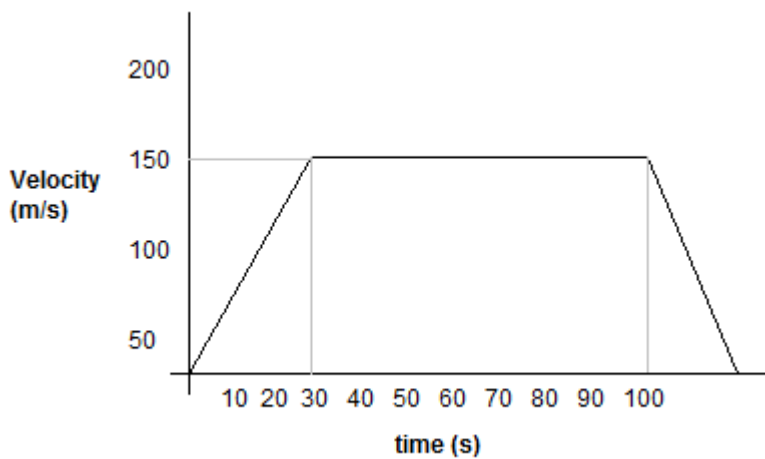

Distance travelled = area under the graph  
 $= \frac{1}{2} (a + b) h$   
 $= \frac{1}{2} (100 + 40) \times 150$

$$= \frac{1}{2} \times 140 \times 150$$
$$= 10500\text{m}$$

#

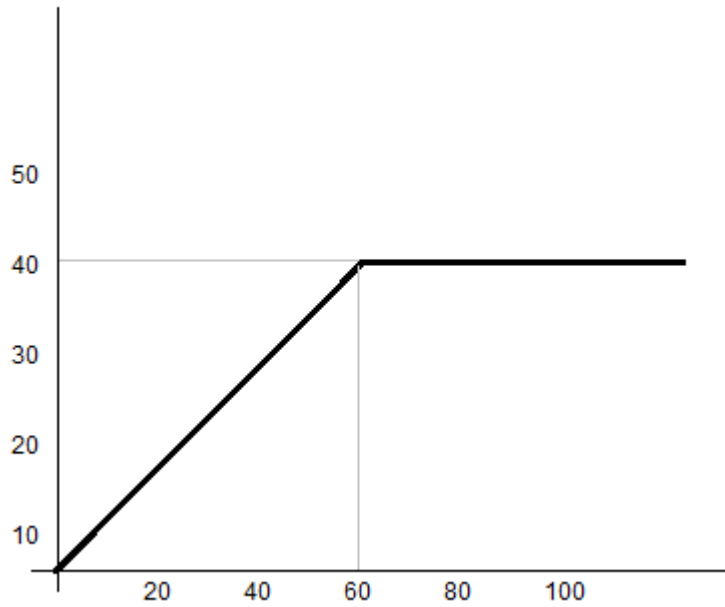

i) Acceleration in first 60s =  $(y_2 - y_1) / (x_2 - x_1)$   
=  $40 - 0 / 60 - 0$   
= 23 meter per second squared

ii) Distance in 100s =  $\frac{1}{2} \times b \times h + l \times b$   
=  $\frac{1}{2} \times 60 \times 40 + 40 \times 60$   
=  $1200 + 2400$   
= 3600 m

iii) Average Speed =  $dt$   
=  $2800 / 100$   
= 28 m/s

#



Maximum speed = 60 m/s

Acceleration =

$$\begin{aligned} \text{Part 1} &= (y_2 - y_1) / (x_2 - x_1) \\ &= 60/20 \\ &= 3 \text{ meter per second squared} \end{aligned}$$

$$\begin{aligned} \text{Part 2} &= (y_2 - y_1) / (x_2 - x_1) \\ &= (40 - 0) / (60 - 40) \\ &= 2 \text{ meter per second squared} \end{aligned}$$

$$\begin{aligned} \text{Part 3} &= (y_2 - y_1) / (x_2 - x_1) \\ &= (40 - 0) / (90 - 80) \\ &= 4 \text{ meter per second squared} \end{aligned}$$

## (c) Forces, movement, shape and momentum

1.9 describe the effects of forces between bodies such as changes in speed, shape or direction

Force is that which can change the state of rest or uniform motion of an object. It is simply pushes and pulls of one thing on another.

If a body is thrown up in the air, what is the effect of gravity on the body? At first gravity reduces the speed of upward movement of the body and at a certain height it stops. So Force effects the speed.

Take a sponge and squeeze it will change its shape.

Throw a ball at a person in one direction. That person will hit the ball again i.e. apply force to the ball and it will change its direction.

To sum up the examples, the effects that occur when a force is applied to an object are:

1. The object may start to move or stop moving.
2. The object may speed up or slow down.
3. The object may change its shape
4. The object may change its direction of movement.

### 1.10 identify different types of force such as gravitational or electrostatic

Different sorts of Force:

1. Gravitational force or weight: The pull of earth due to gravity.
2. Normal Reaction: Simple reaction that stops something when to apply force to it. E.g.: A book is kept on the table which has a normal reaction on it. Otherwise the book would fall down.
3. Air Resistance: The resistivity or drag in the air while an object moves is called Air Resistance. E.g.: When a parachutist open the parachute the movement slows down for the opposite force acting in it.
4. Upthrust: Upthrust force acts only on liquid or air. It pushes an object upwards inspite of gravity. E.g.: A helium balloon moves upwards due to up thrust force.
5. Magnetic: Magnetic force is the attraction force between the poles of magnets.  $N=S$
6. Electrostatic: Electrostatic force is the attraction force between charges.  $+=-$
7. Tension: The pull at both ends of a stretched spring ,string, or rope.
8. Frictional force: the force produced when two objects slide one over another is called frictional force.

### 1.11 distinguish between vector and scalar quantities

Scalar quantities are physical quantities that have magnitude only.

Vector quantities however are physical quantities that possess both magnitude as well as direction.

Scalar	Vector
Mass	Displacement
Time	Velocity
Distance	Acceleration
Speed	Force
Volume	
Density	
Work	
Energy	
Power	

Difference:

Scalar	Vector
Needs only size to express them	Needs both size and direction to express them.
Changes by changing size.	Changes by changing size or direction or even both.
Product of two scalar is a scalar i.e $scalar \times scalar = scalar.$	Products of two vectors can be either be scalar or vector i.e. $vector \times vector = scalar/vector.$

### 1.12 understand that force is a vector quantity



Force is a vector quantity due to the following reasons -

- It has magnitude i.e has the value of its size.
- It has direction.
- When applied force, an object moves with particular motion in a fixed direction.

E.g: Gravitational force has one direction which is downwards. Upthrust has the direction of upwards.

### 1.13 find the resultant force of forces that act along a line

Forces which act along a straight line can be added if the forces are in the same direction or subtracted if the forces are in the opposite direction. The force that you get after adding or subtracting is called the resultant force. The resultant force is a single force that has the same effect as all the other forces combined.



Figure a shows that two forces: 150N and 50N are acting on an object A in the same direction and the object is moving.

Figure b shows that a single force of 200N is acting on the same object and the object moves at the same motion. So 200N is the resultant force of 150N and 50N.

Examples are -

i.



$$\begin{aligned} \text{Resultant force} &= (500 - 200)\text{N} \\ &= 300 \text{ N (towards right)} \end{aligned}$$

ii.



$$\begin{aligned}\text{Resultant force} &= 1000 - 1000 \\ &= 0 \text{ N (rest object)}\end{aligned}$$

### 1.14 understand that friction is a force that opposes motion

Friction is the force that causes moving objects to slow down and finally stop. The kinetic energy of the moving object is converted to heat as work is done by the friction force. Friction occurs when solid objects rub against other solid object and also when objects move through fluids(liquids and gases).

Types of frictions:

- Kinetic friction: The friction that occurs when the object is in motion is called kinetic friction. E.g: Friction deduced in a moving car.
- Static friction: The friction produced when force is applied but the object doesn't move is called static friction. E.g: a block is pulled but it doesn't move because the force is not enough to move it. The friction produced in the block in this situation is the static friction.
- Rolling friction: When an object rolls around another object, a friction is produced. This is called rolling friction. E.g.: The car wheel moves around the axel and rolling friction is produced.
- Fluid friction: The friction produced when two liquid layer side by side moves at different speed is called fluid friction.
- Solid-fluid friction: When a solid moves through a fluid, a friction is produced to the motion. This is called solid-fluid friction.

Causes of friction:

- Ridges and bumps between the surfaces.
- The attraction force between the molecules of containing surfaces.

Ways to reduce friction:

- By making the surface smooth,
- By using lubricating oil such as mobile, grease etc.

Advantages of friction:

- We can walk and run due to friction.
- We can fix a nail in the wall due to friction.
- We can hold a pen due to friction.

Disadvantages of friction:

- Friction causes wear and tear in the surface.
- It reduces the efficiency of the machines.
- There is wastage of energy due to friction.

::: details Experiment: To investigate friction

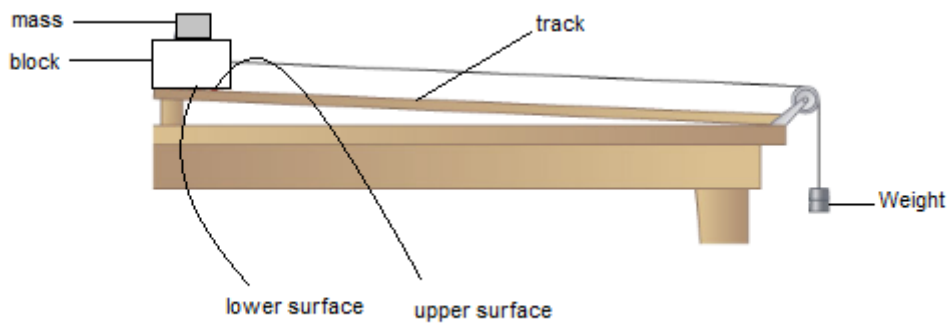

As shown on the diagram above, a block is set on the surface of the track. A nylon line is connected to it which passes over a pulley to a weight. There is friction between the surface of the block and the surface of the track. When the pull of weight equals to the friction then the block starts moving. So the amount of the weight that starts the block to move is equal to the friction.

We can increase the friction by putting some masses over the and we will see that the more is the mass the more is the friction. We can make the track surface rougher such as by using sand paper we will see the friction increases.

:::

### 1.15 know and use the relationship between unbalanced force, mass and acceleration:

**Balanced force:** When two or more forces acting on an object cancel each other and there is no resultant force, then the forces are called balanced force.



200N and 300N are acting towards left on the object A. 500N force is acting on it towards right. The forces cancel each other. So there is no resultant force. So these forces are called balanced forces.

**Unbalanced force:** When two or more forces acting on an object do not cancel each other fully and there is a resultant force, then the forces are called unbalanced force.

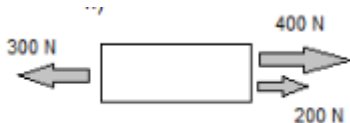

400N and 200N are acting on the object A towards right direction. 300N is acting towards left direction. The forces do not cancel each other fully. There is resultant force of 300N towards right. So their forces are unbalanced.

Force = mass x acceleration

In equation,  $F = ma$  (where,  $m$ =mass and  $a$ =acceleration)

$F \propto a$

Force is directly proportional to acceleration. If force increases acceleration increases.

::: details Experiment: To investigate  $F \propto a$

Working principle - The rate of change of momentum is directly proportional to the applied force and takes place in the direction of force.

Apparatus required -

- Trolley
- Nylon line
- Pulley
- Ramp
- Bench top
- Mass hanger

**Diagram**

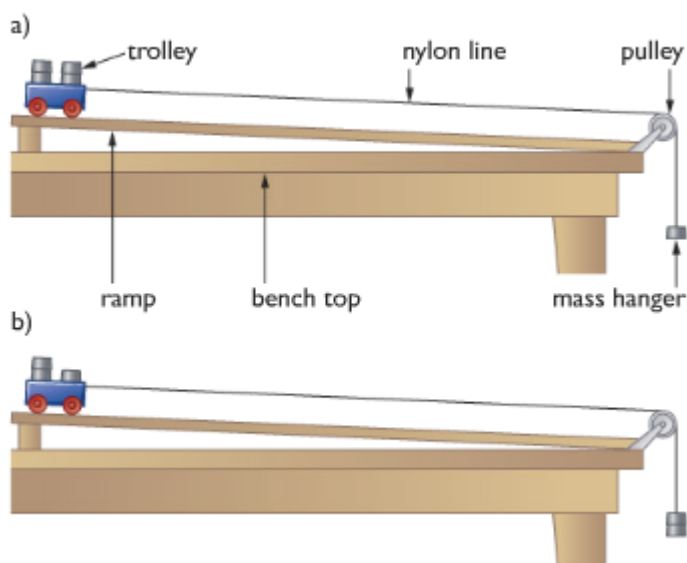

Working procedure: The force acting on the trolley is produced by the masses on the end of the nylon line. As the mass is increased, the trolley accelerates as well, so the force is increased by the transferring one of the masses from the trolley to the mass hanger.

In the diagram, this increases the pulley force on the trolley, while keeping the total mass of the system the same. The acceleration of the trolley can be measured by taking a series of pictures at equal intervals of time using a digital video camera.

Observation: Here, using the digital video camera, as sequences of pictures are taken, the distance travelled from the start for each image is measured, since the time between each image is known, a graph of displacement against time can be drawn. The gradient of the displacement-time graph gives

the velocity at a particular instant, so using the value data for a velocity-time graph can be obtained. The gradient of the velocity-time graph produced is the acceleration of the trolley.

### Graph

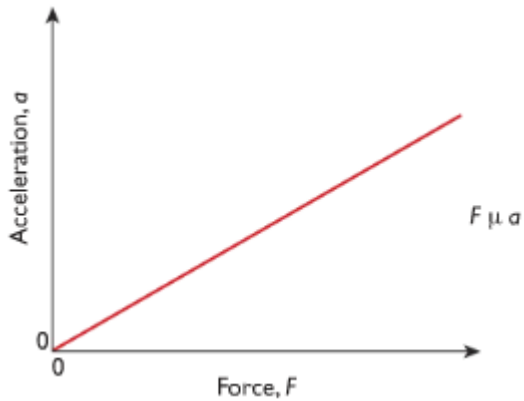

Conclusion: The force and acceleration is same and this produces a straight-line graph which determines that force is directly proportional to force. So doubling the force acting on an object doubles its acceleration.

:::

::: details Experiment: To investigate  $a \propto 1/m$

The same experiment as above, only the force is kept constant and the mass of the trolley is varied.

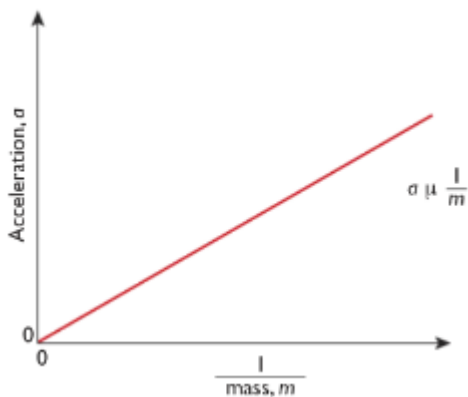

The graph shows the acceleration of the trolley plotted against  $1/m$ . This is also a straight line passing through the origin, showing that acceleration is inversely proportional to mass.

$$a \propto 1/m$$

This means that for a given unbalanced force acting on a body, doubling the mass of the body will halve the acceleration.

Combining Experiment 1 and 2, we get:

$$F = ma$$

One newton is the force needed to make a mass of one kilogram accelerate at one metre per second squared.

:::

### 1.16 know and use the relationship between weight, mass and g:

Weight is the pull of earth. To calculate it, use the formula:

$$\text{Weight} = \text{mass} \times \text{gravitational acceleration}$$

$$W = mg$$

Gravitational field strength: The pull of planet on an object of 1 kilogram is called gravitational field strength. It is also denoted by  $g$ , where in earth  $g = 10 \text{ m/s}^2$  if there is no opposite force.

::: details Experiment: To verify acceleration due to gravity using video camera

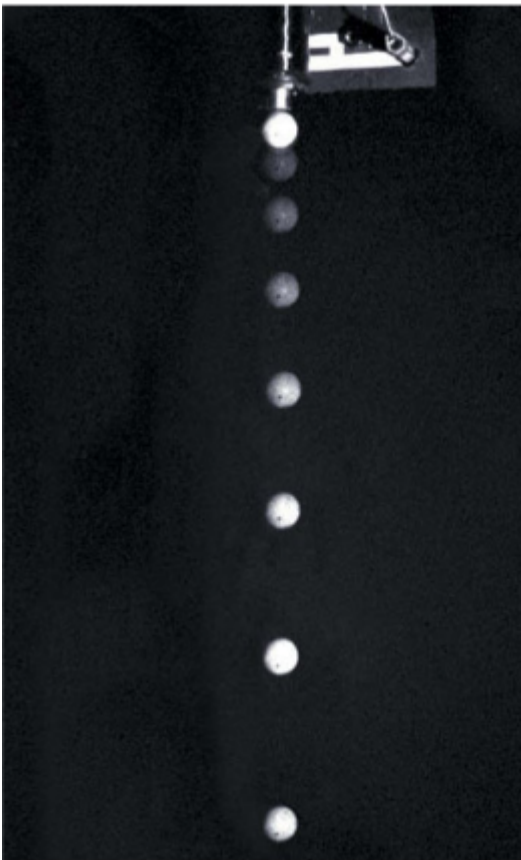

We could measure the distance between two images of the tennis ball – say, the second and the third. This is the distance that the ball travelled during the second interval of one tenth of a second. The average velocity during this time is found by dividing the distance travelled, 14.7 cm, by the time taken, 0.1s. This gives an average velocity of 147 cm/s or 1.47 m/s over the interval. If we repeat the calculation for the next tenth of a second, between 3 and 4m we find the average velocity has increased to 2.45 m/s. We can then use the equation for acceleration.

$$\text{acceleration, } a = \frac{\text{final velocity, } v - \text{initial velocity, } u}{\text{time taken, } t}$$

We find that:

$$a = \frac{2.45 \text{ m/s} - 1.47 \text{ m/s}}{0.1 \text{ s}} = 9.8 \text{ m/s}^2$$

The result of this experiment gives us a value for acceleration caused by the force of gravity.

:::

::: details Experiment: To measure acceleration due to gravity using electromagnet

**Apparatus:** Millisecond timer, metal ball, trapdoor and electromagnet.

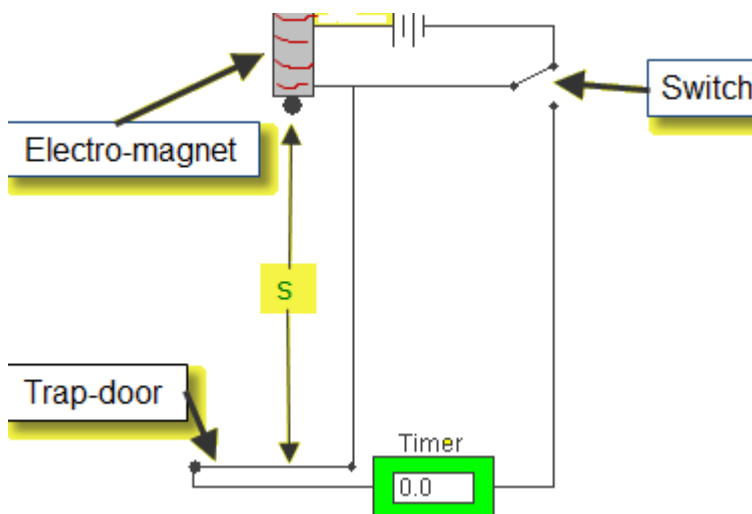

**Procedure:**

1. Set up the apparatus as shown. The millisecond timer starts when the ball is released and stops when the ball hits the trapdoor.
2. Measure the distance,  $s$  using a meter stick.
3. Flick the switch to release the ball and record the time,  $t$  from the millisecond timer.
4. Repeat for different values of  $s$ .
5. Calculate the values of  $g$  using the equation  $s = (g/2) t^2$ . Obtain an average value for  $g$ .
6. Draw a graph of  $s$  against  $t^2$  and use the slope to find the value for  $g$ .

**Precautions/ Source of error:**

1. For each height  $s$  repeat three times and take the smallest time as the correct value for  $t$ .
2. Place a piece of paper between the ball bearing and the electromagnet to ensure a quick release.
3. Remember to convert from milliseconds to seconds.

:::

**1.17 describe the forces acting on falling objects and explain why falling objects reach a terminal velocity**

Terminal velocity is the steady velocity of a falling object whose drag is balanced by the weight.

**How does a falling object reach terminal velocity?**

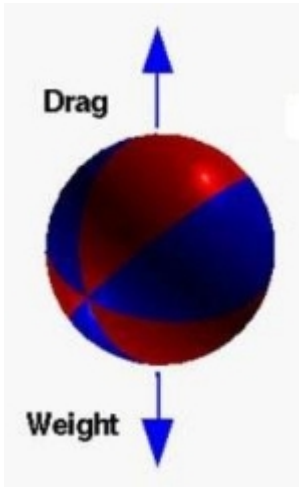

In a free falling object two types of force acts: Drag and Weight. The size of the drag force acting on an object depends on its shape and its speed. If the drag force of an object increases to a point which is equal to Weight, then the acceleration stops. It falls in a constant velocity known as terminal velocity.

**Reaching terminal velocity on a parachute**

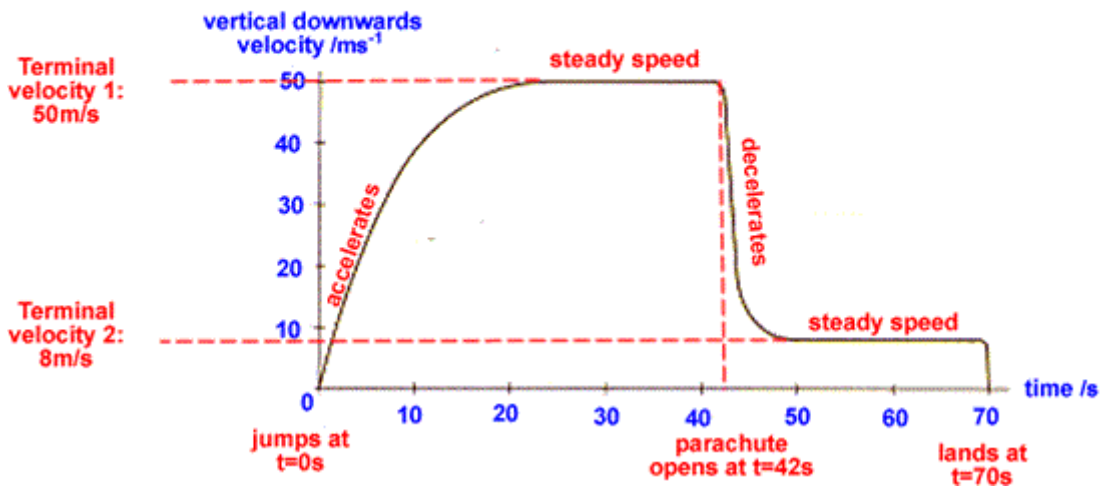

When a skydiver jumps from a plane at high altitude he will accelerate for a time and eventually reach terminal velocity. When she will open her parachute, this will cause a sudden increase in the drag force. At that time drag force will be higher than the weight and he will decelerate for some time. Later those forces will become equal and reach a new terminal velocity.



### **1.18 describe experiments to investigate the forces acting on falling objects, such as sycamore seeds or parachutes**

#### **Sycamore seeds**

We can measure the weight of the sycamore seeds using an electric balance. Now the sycamore seed is released from a high point. We will use a digital video camera to take the snaps of the moving seed. The video camera can take 25 snaps in one second. We can measure the acceleration of the ball at any point using the snaps of the moving seed. Now multiplying the mass of the seed by acceleration at any point we can find the unbalanced force acting on it. If we subtract the unbalanced weight from its weight, we will get the air resistance acting on the seed.

#### **Parachutes**

When a parachute is released only the weight acts on it. We can use a force meter to determine the weight. When the parachute falls downward, air resistance acts on it in the upward direction. So the downward unbalanced force decreases. The force meter attached to the parachute gives a lower reading. As the parachute goes down the speed increases. The drag force also increases. The reading on the force meter decreases as well. A moment comes when the drag force becomes equal to the weight. In this situation the reading in the force meter becomes zero. If we want to find the air resistance at any momentum we will have to subtract the weight from the unbalanced force. This is how we can investigate the forces acting on a falling object.

### **1.19 describe the factors affecting vehicle stopping distance including speed, mass, road condition and reaction time**

Stopping distance: The stopping distance is the sum of Thinking distance and Braking distance.

Thinking distance: The distance travelled after seeing an obstacle and till reaction.

Braking distance: The distance travelled after the brakes are applied.

The thinking distance depends on the following factors -

1. Whether the driver is tired or has taken alcohol or drugs.
2. On the visibility power of the driver.
3. On the speed of the car.

The braking distance depends on the following factors -

1. **Speed of the car:** The more the speed is, the more the braking distance will be;  $S \propto v^2$ .
2. **Mass of the car:** As acceleration is equal to  $F/m$ , for constant braking force, the more is the mass, the less is the deceleration, the more is the braking distance.
3. **Road condition:** If the road is rough, the braking distance will be less.
4. **Tyre condition:** If the tyre is new (rough), there will be less braking distance.
5. **Braking system:** For loose braking system, the braking distance will be more.

### **1.20 know and use the relationship between momentum, mass and velocity:**

Momentum is a quantity possessed by masses in motion (product of mass and velocity). Momentum is measure of how difficult it is to stop something that is moving. We calculate the momentum of a moving object using the formula:

Momentum,  $p$  (kg m/s) = mass,  $m$ (in kg) x velocity,  $v$  (in m/s)

$$P = m \times v$$

### 1.21 use the idea of momentum to explain safety features

Objects in a car have mass, speed and direction. If the object, such as a person, is not secured in the car they will continue moving in the same direction (forward) with the same speed (the speed the car was going) when the car abruptly stops until a force acts on them.

Every object has momentum. Momentum is the product of a passenger's mass and velocity (speed with a direction). In order to stop the passenger's momentum they have to be acted on by a force. In some situations the passenger hits into the dashboard or windshield which acts as a force stopping them but injuring them at the same time.

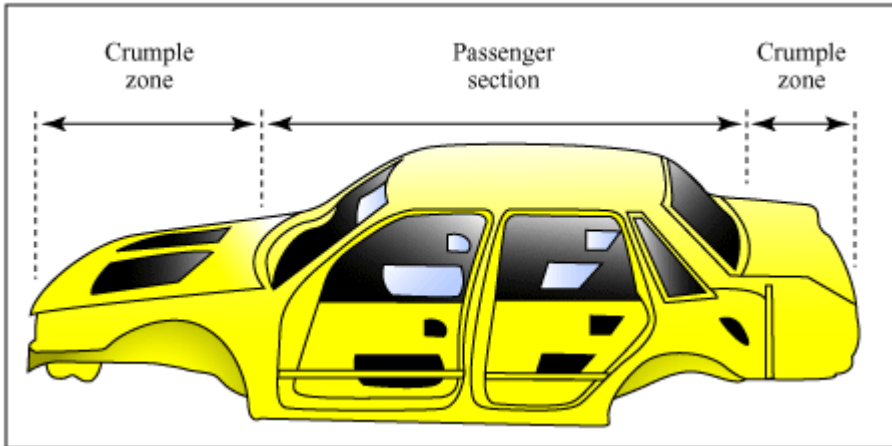

#### 1 Crumple Zone

Cars are now designed with various safety features that increase the time over which the car's momentum changes in an accident. Crumple zones are one of the safety features now used in modern cars to protect the passengers in an accident. The car has a rigid passenger cell with crumple zones in front and behind. During a collision, it increases the time during which the car is decelerating. This also reduce the force impacting on the passenger increasing their chances of survival.



#### 2 Air Bags

Many cars are now fitted with air bags to reduce the forces acting on passengers. The purpose of an airbag is to help the passenger in the car reduce their speed in collision without getting injured. An airbag provides a force over time. This is known as impulse. The more time the force has to act on the passenger to slow them down, the less damage caused to the passenger.

**1.22 use the conservation of momentum to calculate the mass, velocity or momentum of objects**

If a moving object hits another slow or stationary object, it will result an equal force to both of the objects (according to Newton's Third Law). That forces act in opposite directions and obviously for the same amount of time. This means the  $F \times t$  for each is the same size. The moving object lost its momentum while the stationary object gained its momentum. So it is balanced. The total moment of the two objects is unchanged before and after the collision- *momentum is conserved*.

Momentum before the collision = momentum after the collision

$$m_1u_1 + m_2u_2 = m_1v_1 + m_2v_2.$$

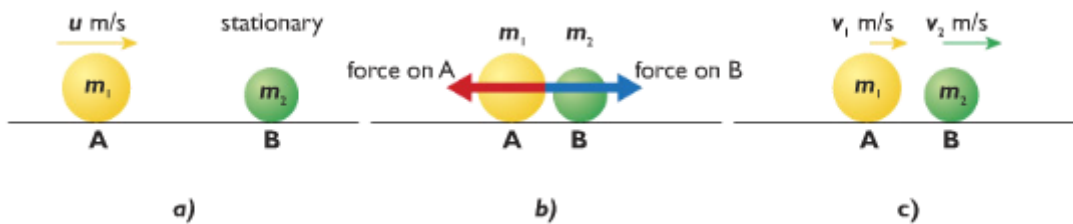

Elastic and inelastic collisions

In a collision, if the kinetic energy remains conserved, the collision is called elastic collision.

**Example** - Collision between two gas molecules.

In a collision if the kinetic energy does not remain conserved, the collision is called inelastic collision.

**Example** - Collision between a truck and a micro-bus.

Application of momentum principle: Explosion

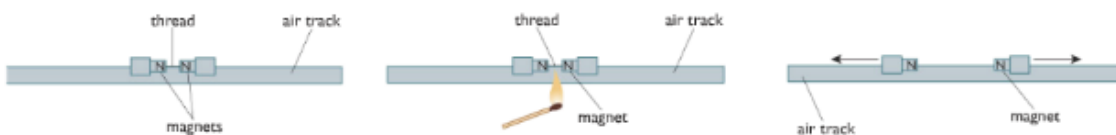

Two gliders are tied by a thread while the two ends contain two like poles of a magnet. The gliders are on the air track. Using a match stick we can burn the thread. When the thread is cut, the two gliders move away in opposite direction. If the masses of the two gliders are same, the speed of the gliders will also be equal. It means that the momentum of the two gliders is equal and opposite. That is the total momentum difference is zero which was the same before the collision. It verifies the law of conservation of momentum.

<b>Before collision</b>	<b>After collision</b>
-------------------------	------------------------

Both rest	Both can stop
Both moving	Both moving (same/ opposite)
One moving	Both can be one object

Law of conservation of momentum is only verified if two forces act on it - action & reaction.

### Application of momentum principle: Rockets

Rocket motors use the principle of conservation of momentum to propel spacecraft through space. They produce a continuous, controlled explosion that forces large amount of fast-moving gases (produced by fuel burning) out of the back of the rocket. The spacecraft gains an equal amount of momentum in the opposite direction to that of the moving exhaust gases and moves upward with a very high speed.

### 1.23 use the relationship between force, change in momentum and time taken:

Initial momentum of object =  $mu$

Final momentum =  $mv$

Therefore increase in momentum =  $mv - mu$

<b>Rate of increase of momentum</b>	<b><math>= (mv - mu)/t</math></b>
	$= m(v - u)/t$
	$= ma = \text{Force}$

Force = Rate of increase of momentum

Force = Change in momentum / time

### 1.24 demonstrate an understanding of Newton's third law

Newton's third law: "For every action there is an equal and opposite reaction."

Newton's third law states four characteristics of forces:

- Forces always occur in pairs (action and reaction force.)
- The action and reaction are equal in magnitude.
- Action and reaction act opposite to one another.
- Action and reaction act on different bodies.
- Action and reaction do not cancel each other

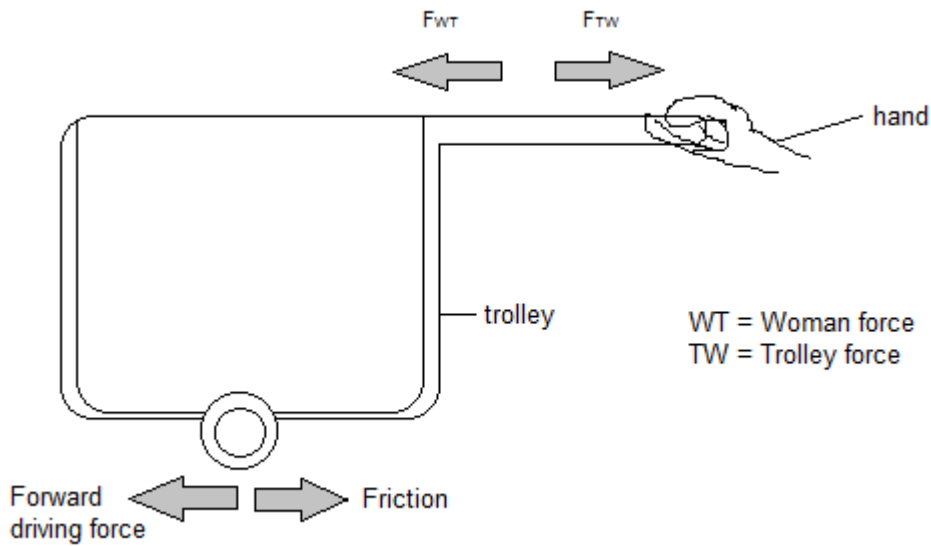

**1.25 know and use the relationship between the moment of a force and its distance from the pivot:**

moment = force \* perpendicular distance from the pivot

moment =  $F * d$

The turning effect of a force about a hinge or pivot is called its moment. In other words, it is the product of force and the perpendicular distance from the pivot to the line of action of the force. It is measured in Newton meter (Nm).

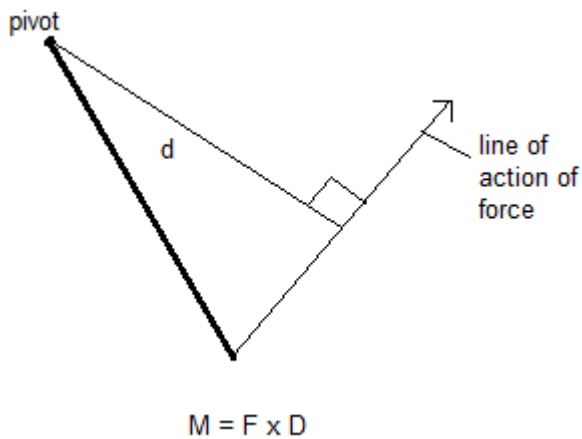

There are two types of moment: (i) Clockwise moment & (ii) Anti-clockwise moment

When a force causes an object to turn in a clockwise direction, it is called a Clockwise Moment.

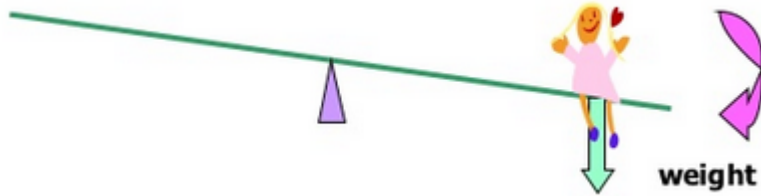

When a force causes an object to turn in an anti-clockwise direction, it is called a Anti-clockwise moment.

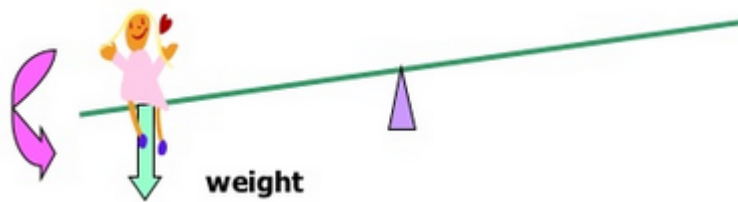

**1.26 recall that the weight of a body acts through its centre of gravity**

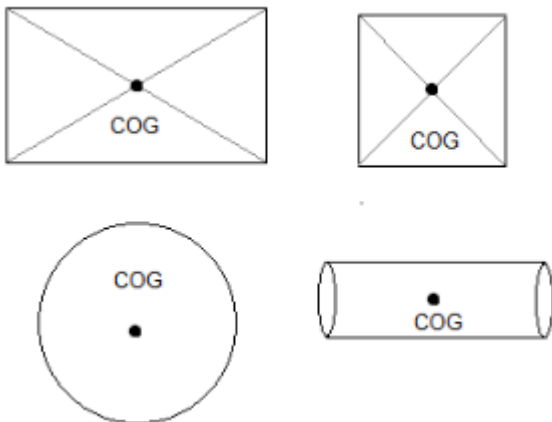

Mass is the amount of matter an object has. Every part of an object forms part of its overall mass. But when we try to balance an object on a point, there will only be one place where it will balance. You can therefore think of the mass of an object being concentrated at this point, known as the centre of mass or gravity.

If we support the centre of gravity of the object, the object won't fall no matter how wide it is. Because the moment of the all sides are balanced and there will be no clockwise or anti-clockwise movement.

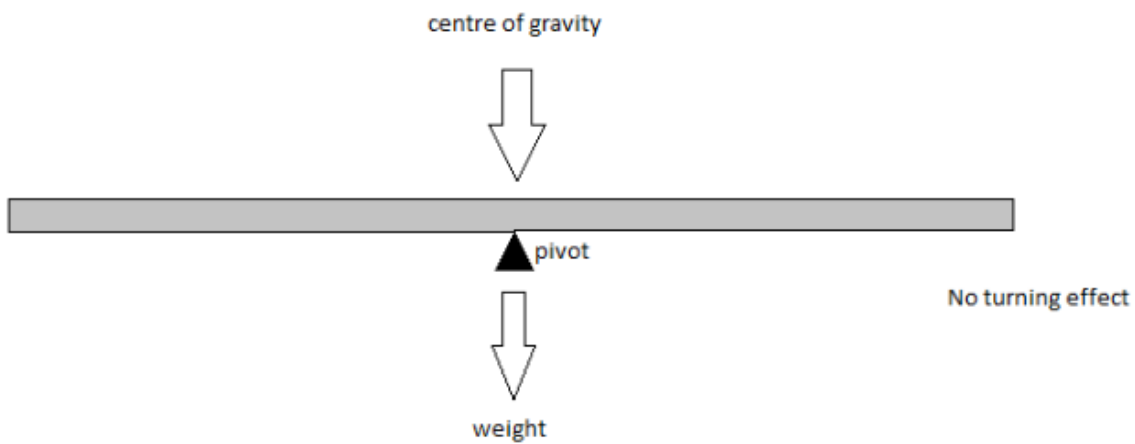

### Stability of centre of gravity

A stable object is one that is difficult to push over; when pushed and then released it will tend to return to its original position. Stability can be increased by:

1. By increasing the base area.
2. By decreasing the height of COG.

::: details Experiment: To determine the position of the centre of gravity of an uniform object using balancing method

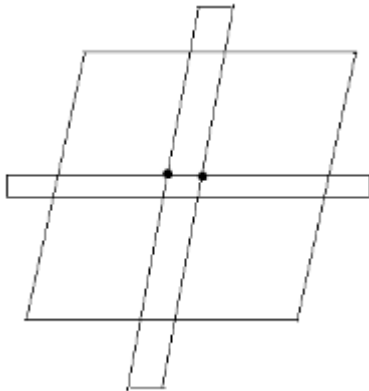

Balance the object keeping over a scale and draw the line of contact. Balance the object on another axis keeping it over the same scale and draw the line of contact again. The two lines intersect at a point. This point gives the COG.

:::

::: details Experiment: To determine the position of the centre of gravity of a plane lamina with irregular shape of non-uniform thickness or density

**Apparatus:** Retord stand, plumblin, cork and pin

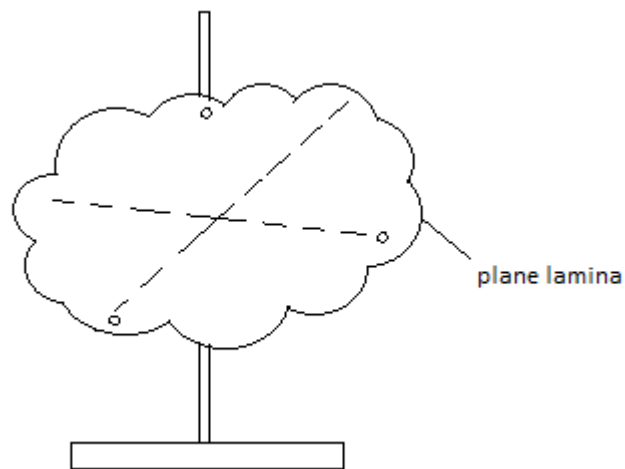

**Procedure:**

1. Make three small holes near the edge of the lamina. The holes should be as far apart as possible from one another.
2. Suspend the lamina through one of the holes using a pin.
3. Hang a plumbline on the pin in front of the lamina.
4. When the plumbline is steady, draw a line on the lamina over the plumbline.
5. Repeat the above for other two holes.
6. The point of intersection of the three lines is the position of the centre of gravity.

**Precautions:**

1. The holes must be small so that not too much of the lamina is removed.
2. The lamina should be free to swing above its point of suspension.

:::

**1.27 know and use the principle of moments for a simple system of parallel forces acting in one plane**



# Principle of Moments



For an object to be in equilibrium (stable/not moving), the total clockwise moment must be equal to the anticlockwise moment about the same pivot point.

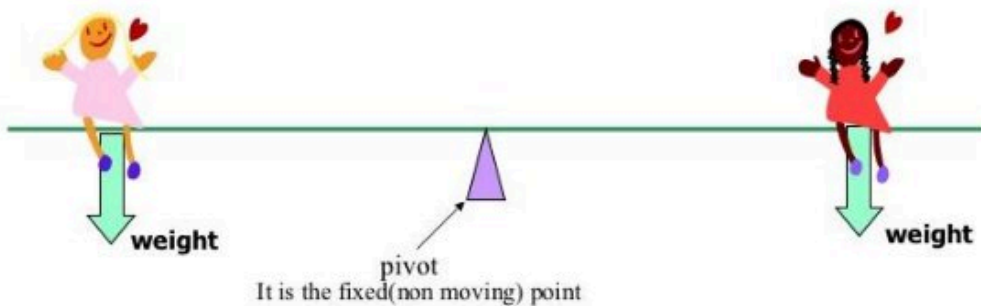

## Solving Problems related to Principle of Moments

::: details Example 1

Step 1:

Identify what are forces that will give rise to clockwise / anti-clockwise moment



Step 2:

Find the clockwise / anticlockwise moment



Find the value of d.

Solution:

$$\begin{aligned} \text{Clockwise moment} &= \text{Force} \times \text{distance between force and pivot} \\ &= 30 \times d \\ &= 30d \text{ Nm} \end{aligned}$$

$$\begin{aligned} \text{Anticlockwise moment} &= \text{Force} \times \text{distance between force and pivot} \\ &= 10 \times 6 \\ &= 60 \text{ Nm} \end{aligned}$$

Step 3:

Equate the clockwise and anticlockwise moments

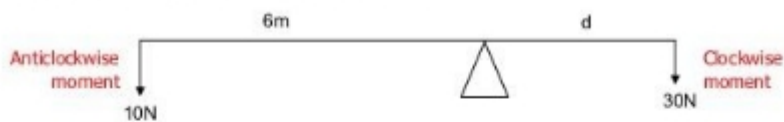

Find the value of d.

Solution:

$$\begin{aligned} \text{Clockwise moment} &= \text{Force} \times \text{distance between force and pivot} \\ &= 30 \times d \\ &= 30d \text{ Nm} \end{aligned}$$

$$\begin{aligned} \text{Anticlockwise moment} &= \text{Force} \times \text{distance between force and pivot} \\ &= 10 \times 6 \\ &= 60 \text{ Nm} \end{aligned}$$

Using the principle of moments,

$$\begin{aligned} \text{Clockwise moment} &= \text{Anti-clockwise moment} \\ 30d &= 60 \\ d &= 60 \div 30 \\ d &= \underline{2\text{m}} \end{aligned}$$

:::

::: details Example 2

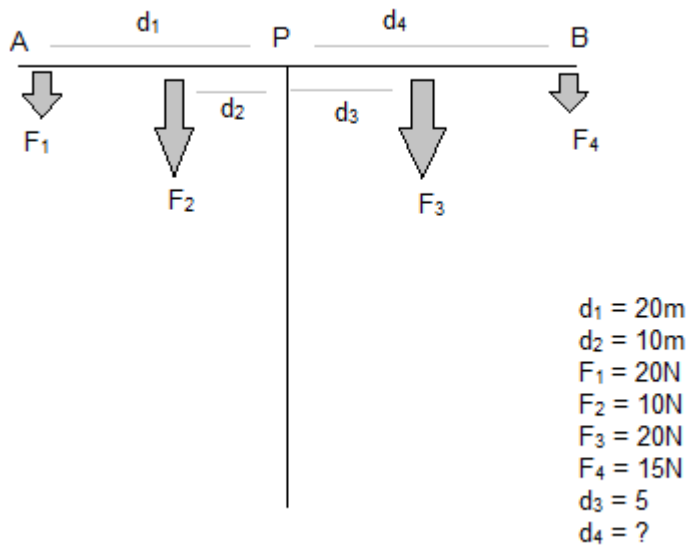

$$F_2 d_2 + F_1 d_1 = F_3 d_3 + F_4 d_4$$

$$10 \times 20 + 20 \times 10 = 5 \times 20 + 15 \times d_4$$

$$400 - 100 = 15 \times d_4$$

$$d_4 = 300/15$$

$$d_4 = 20\text{m}$$

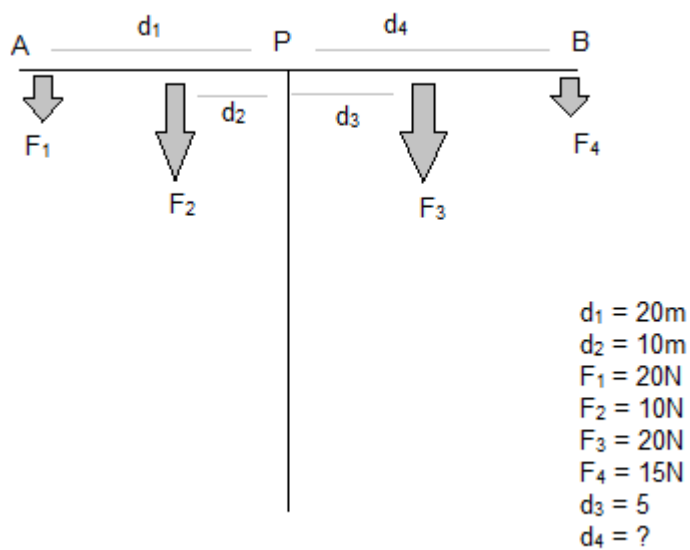

...tip

$$F_2 d_2 + F_1 d_1 = F_3 d_3 + F_4 d_4$$

$$10 \times 20 + 20 \times 10 = 5 \times 20 + 15 \times d_4$$

$$400 - 100 = 15 \times d_4$$

$$d_4 = 300/15$$

$$d_4 = 20\text{m} \therefore$$

$\therefore$  details Example 3

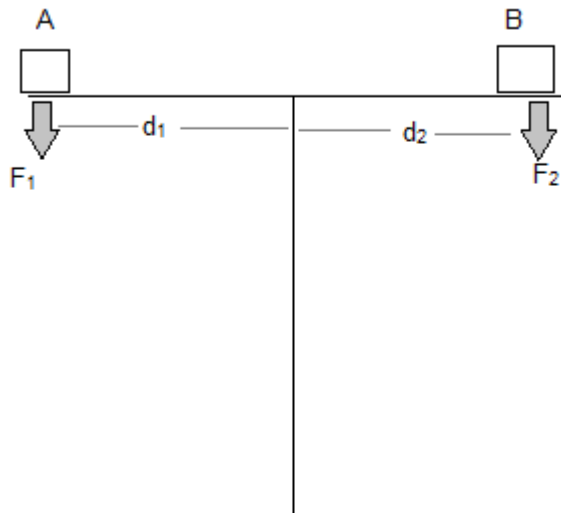

At position A, the object is of 400N at a distance 1.5m from the pivot. What should be the distance of object B from the pivot is of 500N and the see-saw is at equilibrium position.

At equilibrium, sum of clockwise moment = sum of anti-clockwise moment

$$F_1 d_1 = F_2 d_2$$

$$400 \times 1.5 = 500 \times d_2$$

$$d_2 = 600/500$$

$$d_2 = 1.2 \text{ m}$$

$\therefore$

$\therefore$  details Example 4

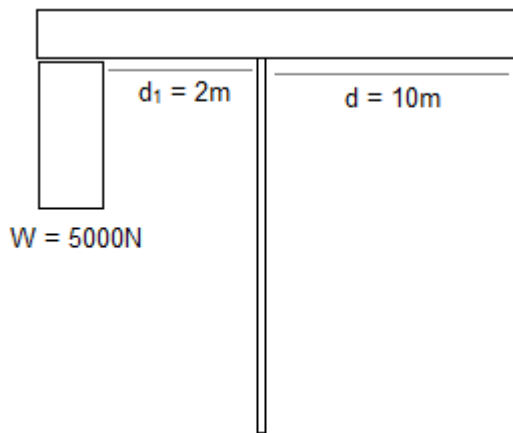

In a crane, the force arm  $d_1 = 2\text{m}$  and weight of  $5000\text{N}$  is put at the force arm. What maximum load the crane can raise in the load arm  $d_2$  is  $10\text{m}$ ?

Sum of CWM = Sum of ACWM

$$W \times d_1 = F \times d_2$$

$$F = W \times d_1 / d_2$$

$$F = 5000 \times 2 / 10$$

$$F = 1000\text{N}$$

∴

∴ details Experiment: To verify the principle of moment

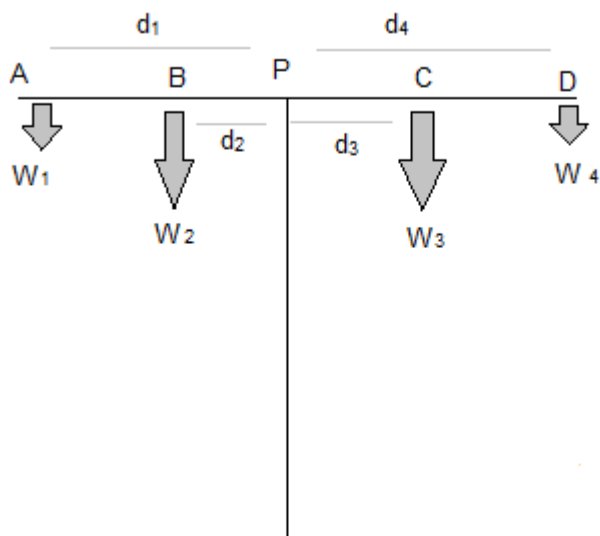

A uniform beam AD is put at point P on a support.

The beam is balanced.

Now, we will put four different beam at different distances in a way so that the beam restores the balance again.

Now, calculate the moment for the weights

$$\text{Moment for } W_1 = W_1d_1$$

$$\text{Moment for } W_2 = W_2d_2$$

$$\text{Moment for } W_3 = W_3d_3$$

$$\text{Moment for } W_4 = W_4d_4$$

$$\text{Now, sum of clockwise moments} = W_3d_3 + W_4d_4$$

$$\text{Sum of anti-clockwise moments} = W_1d_1 + W_2d_2$$

$$\text{Now, if we put the values of constants, we will see that } W_1d_1 + W_2d_2 = W_3d_3 + W_4d_4$$

i.e. Sum of anti-clockwise moment = sum of clockwise moment

So the principle of moment is verified.

:::

**1.28 understand that the upward forces on a light beam, supported at its ends, vary with the position of a heavy object placed on the beam**

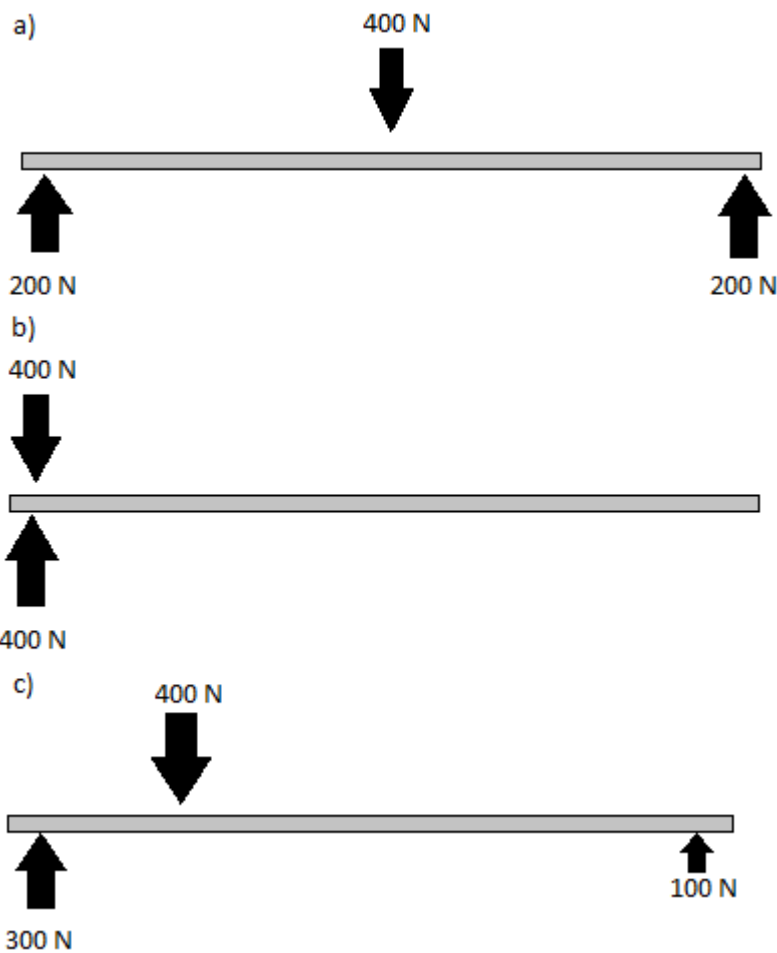

a) An object weighing 400 N is placed in the middle of the beam. The beam is not moving, so the upward and downward forces must be balanced.

b) As the object is placed in the middle of the beam, the upward forces on the ends of the beam are same as each other. If it is moved right to one end of the beam, then the upward force will all be at that end of the beam. As it is moved along the beam, the upward forces at the ends of the beam change.

In c) he is  $\frac{1}{4}$  away from the plant. The upward force on the support nearest to him is  $\frac{3}{4}$  of his weight and the upward force on the end of furthest beam is only  $\frac{1}{4}$  of his weight.

$$x + y = 400x * \frac{1}{4} = y * \frac{3}{4}x * \frac{1}{4} = (400 - x) * \frac{3}{4}x = 3(400 - x)x = 1200 - 3x^2 = 1200x = 300$$

$$y = 400 - x = 400 - 300 = 100$$

### 1.29 describe experiments to investigate how extension varies with applied force for helical springs, metal wires and rubber bands

::: details Experiment: Investigating extension with applied force in spring

Apparatus:

- Spring/Wire/Rubber-band
- Scale
- Some masses
- Clamp and stand
- Mass hanger

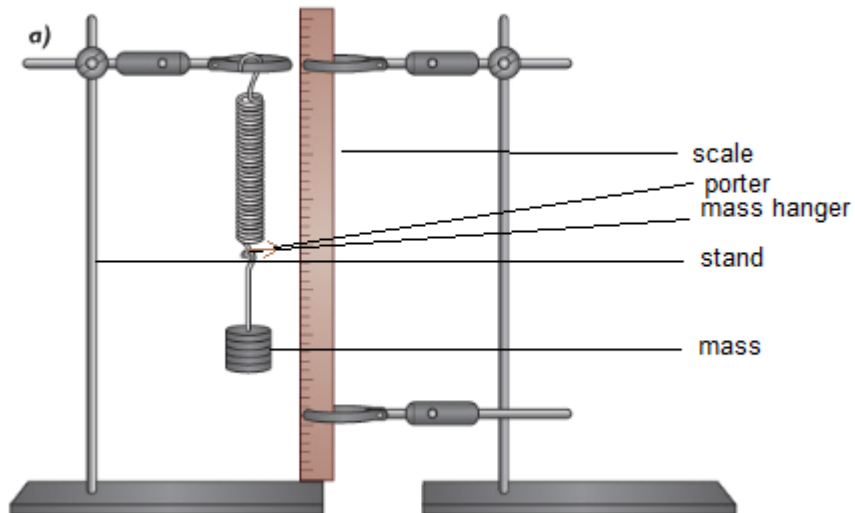

Working procedure:

1. Take the length of the normal condition.
2. Add a mass in the mass hanger and determine the extension by using the porter and the scale.
3. Add another mass gradually and determine the extension in all cases.
4. Plot a graph of extension and relevant loads.

Observation with helical spring:

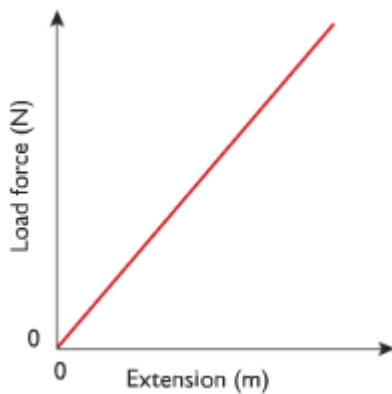

Since the graph of load & extension is a straight line, which proves the extension and load are directly proportional.

Observation with rubberband:



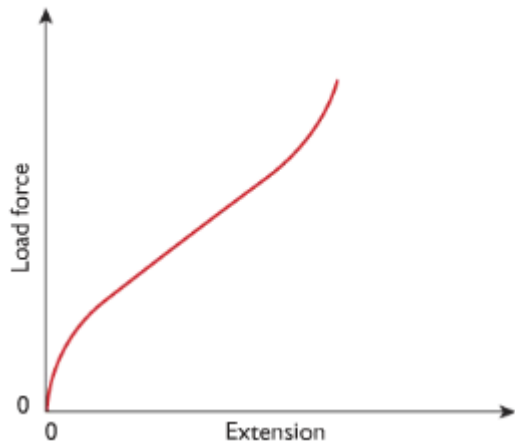

Since the graph didn't produce a straight line, extension is not directly proportional to load force. But extension still increases as the force is applied.

Observation with metal wire:

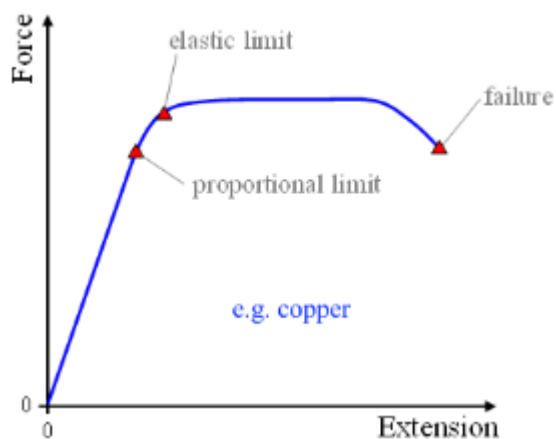

∴

**1.30 understand that the initial linear region of a force-extension graph is associated with Hooke's law**

Hooke's law, "Within the elastic limit, extension is directly proportional to the load i.e.  $e \propto f$ "

Hooke measured the increase in length (extension) produced by different load forces on springs. The graph he obtained by plotting force against extension looked like that below. This straight line passing through the origin shows that the extension of the spring is proportional to the force. The relationship is known as *Hooke's law*.

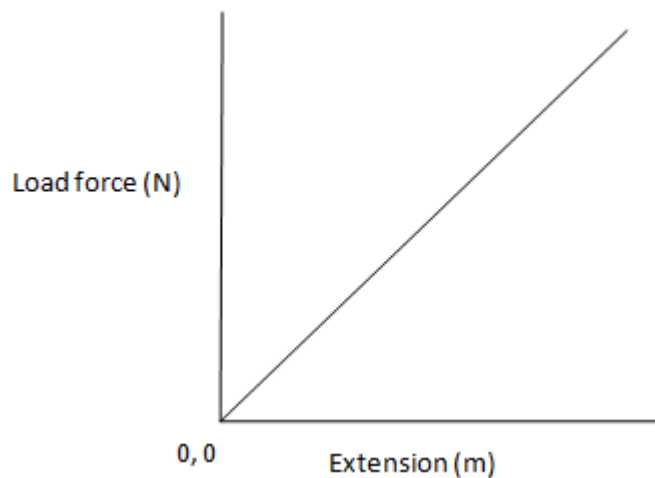

Hooke's Law only applies if you do not stretch a spring too far. At a point the elastic limit it starts to stretch more for each successive increase in the load force. Once you have stretch a spring beyond this limit it has changed shape permanently and will not return to its original shape.

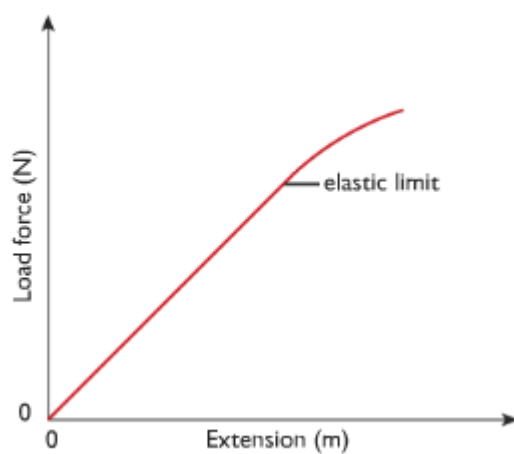

**1.31 describe elastic behaviour as the ability of a material to recover its original shape after the forces causing deformation have been removed.**

Objects showing elastic behaviour has the ability to return to its original shape after the forces causing its shape are removed. This property is called elasticity. Examples of objects showing elastic behaviour are coiled springs.

Uses of spring:

1. Use to absorb bumps in the road or suspension spring in the car or cycle.
2. In beds and furnitures they used to make sleeping and sitting more comfortable.
3. Used in door locks to hold bolts and catches closed and to make doors close automatically.
4. Used in measuring devices like spring balance or bathroom scales.

The materials which do not exhibit elasticity i.e. they do not return to its original position after stretching force is removed are called plastic materials. Examples are putty, plasticine.

## Section 2: Electricity

[[toc]]

### (a) Units

**2.1 use the following units: ampere (A), coulomb (C), joule (J), ohm ( $\Omega$ ), second (s), volt (V), watt (W).**

- Unit of current: ampere (A)
- Unit of charge: coulomb (C)
- Unit of energy: Joule (J)
- Unit of resistance: ohm ( $\Omega$ )
- Unit of time: second (s)
- Unit of voltage or potential difference: volt (V)
- Unit of Power: watt (W)

### (b) Mains electricity

**2.2 understand and identify the hazards of electricity including frayed cables, long cables, damaged plugs, water around sockets, and pushing metal objects into sockets**

Mains electricity: The source of electricity in our houses is called mains electricity.

Electricity meter: The meter that measures the electrical energy we consume in our house is called electricity meter.

Fuse box(or Consumer unit): The box that contains all fuse and circuit breakers in a circuit is called fuse box.

Ring main circuit: Wires that leave the fuse box are hidden in the walls or floors around each room. These wires are connected to form ring main circuits. Individual equipments are connected to these circuits using plugs. It consists of three wires: live wire, neutral wire and earth wire.

Live wire: The wire that contains the electricity all the time is called live wire.

Neutral wire: The wire that usually doesn't contain the electricity but when it is connected with the live wire then it also become live. The neutral wire completes the circuit.

Earth wire: The earth wire usually has no current flowing through it. It is there to protect user if an appliance develops a fault.

Electricity is very useful, but it can be dangerous if it is not used safely. The following hazards that increase the chances of severe and possibly fatal electric shocks are:

- frayed cables, any damaged insulation can expose 'live' wires.
- Long cables, as they are more likely to get damaged or trip people up.
- Damage to plugs or any insulating casing on any mains operated devices.
- Water around electric sockets or mains operated devices.
- Pushing metal objects into the mains sockets – usually only a problem with very young children, solved by using socket covers.

### **2.3 understand the uses of insulation, double insulation, earthing, fuses and circuit breakers in a range of domestic appliances**

**Insulation:** Some appliances are cased with insulators like plastic rather than metal to prevent user from receiving shock. This casing is called insulation.

**Double Insulation:** Some appliances are double insulated; as well as all their wiring being insulated the outer casing of the appliances is also made of an insulating material. This means there is no chance of an electric shock from the casing – double insulation is often used with electric kettles and power tools like electric drills.

**Earthing:** Many appliances have a metal casing. This should be connected to earth wire so that if the live wire becomes frayed or breaks and comes into contact with the casing, the current will pass through the earth wire rather than the user. The current in the earth wire is always large enough to blow the fuse and turning off the circuit. So the user is safe from electric shock.

**Fuses:** Fuse is a safety device usually in the form of a cylinder or cartridge which contains a thin piece of wire made from a metal that has low melting point. If too large a current flows in the circuit the fuse wire becomes very hot and blows, shutting the circuit off. This prevents you getting a shock and reduces the possibility of an electrical fire. Once the fault in the current is corrected, it should be replaced again.



**Circuit Breakers or Trip switches:** Circuit Breaker is similar to fuses. If too large a current flows in a circuit a switch opens making the circuit incomplete. Once the fault in the circuit is corrected, the switch is reset, usually by pressing a reset button.

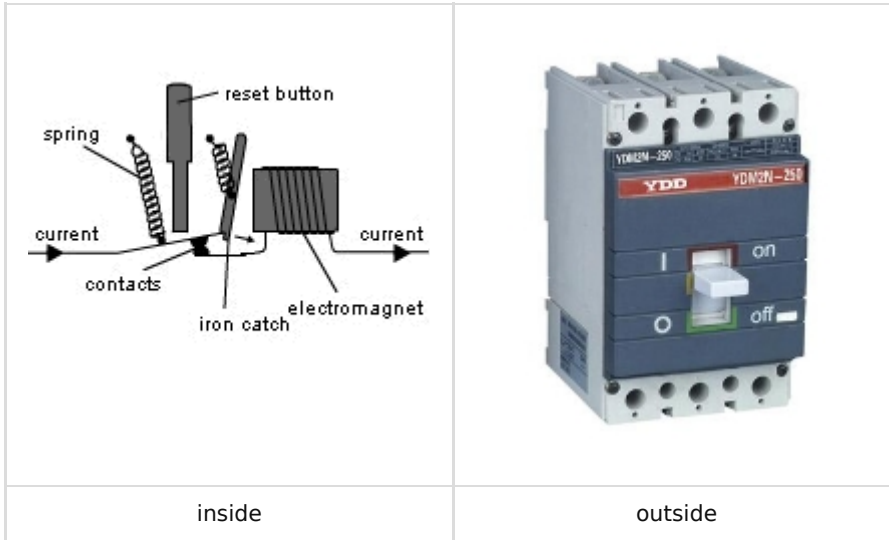

How does a circuit breaker work?

When high current flows, the electromagnet in it gains its magnetism and attract the iron catch towards it. This separated the contact and the circuit discloses.

Switches: Switches in main circuit should always be included in the live wire so that when the switch is open, no electrical energy can reach an appliance. If the switch is included in the neutral wire, electrical energy can still enter an appliance, and could possibly cause an electric shock.

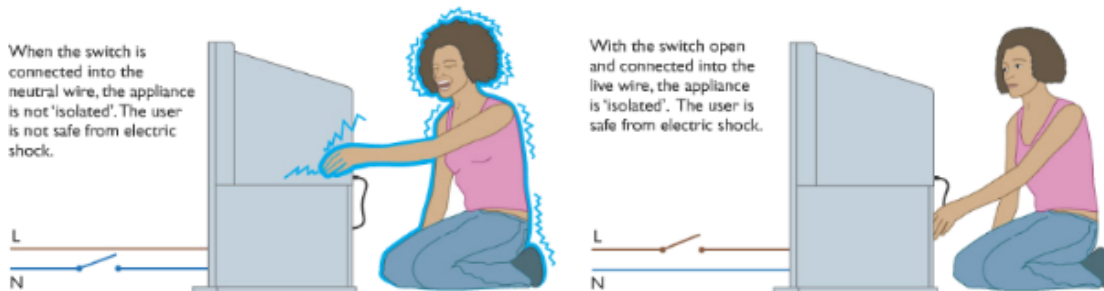

**2.4 understand that a current in a resistor results in the electrical transfer of energy and an increase in temperature, and how this can be used in a variety of domestic contexts**

Normal wiring in the house are said to have low resistance and the current pass through them easily. Heating elements like nichrome wire have high resistance. When current flows through them current cannot pass, and the energy is transferred to heat energy and the element heats up. It is also used in the lights - normal light bulbs have a very thin filament which gets so hot when current passes through it that it glows white. We use the heating effect of current in electric kettle, iron, filament lamps, fan heaters, hair dryers etc.

**2.5 know and use the relationship: power = current × voltage,  $P = I \times V$  and apply the relationship to the selection of appropriate fuses**

Power is amount that represents how much voltage or energy is converted every second. It is calculated using this equation:

Power, P (in watts) = current, I (in amps) x voltage, V (in volts)

$$P = I \times V$$

Fuses in plugs are made in standard ratings. The most common are 3A, 5A and 13A. The fuse should be rated at a slightly higher current than the device needs:

- if the device works at 3A, use a 5A fuse
- if the device works at 10A, use a 13A fuse

## 2.6 use the relationship between energy transferred, current, voltage and time:

Energy transferred = current × voltage × time

$$E = I \times V \times t$$

The power of an appliance (P) tells you how much energy it converts each second. This means that the total energy (E) converted by an appliances is equal to its power multiplied by the length of time the appliance is being used.

Total energy, E (in joules) = power, P (in watts) × time, t (in seconds)

$$E = P \times t$$

Since,  $P = I \times V$

$$E = I \times V \times t$$

## 2.7 understand the difference between mains electricity being alternating current (a.c.) and direct current (d.c.) being supplied by a cell or battery.

### Alternating current:

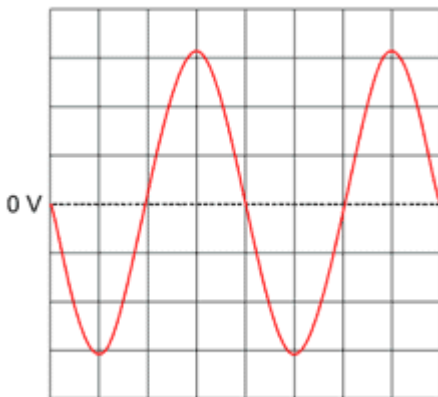

If the current constantly changes direction, it is called alternating current, or a.c.. Mains electricity is an a.c. supply, with the UK mains supply being about 230V. It has a frequency of 50Hz (50 hertz), which means it changes direction, and back again, 50 times a second. The diagram shows an oscilloscope screen displaying the signal from an a.c. supply. Alternating current is useful in electricity generator and transformers.

### DIRECT CURRENT (DC)

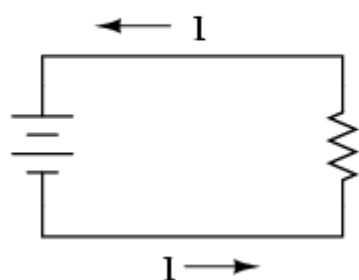

### ALTERNATING CURRENT (AC)

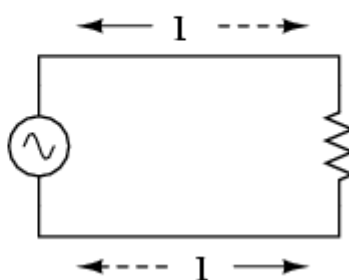

#### Direct current:

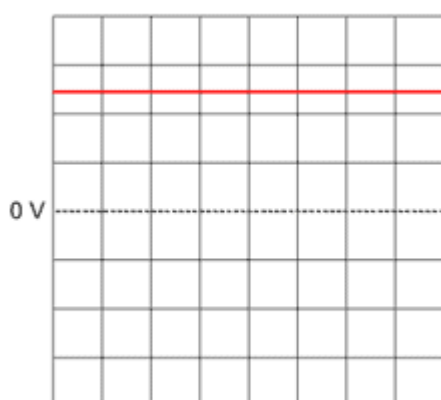

If the current flows in only one direction it is called direct current, or d.c. Batteries and cells supply d.c. electricity, with a typical battery supplying maybe 1.5V. The diagram shows an oscilloscope screen displaying the signal from a d.c. supply.

Alternating current can be converted to direct current by using a rectifier. This direct current is made uniform by filter circuit.

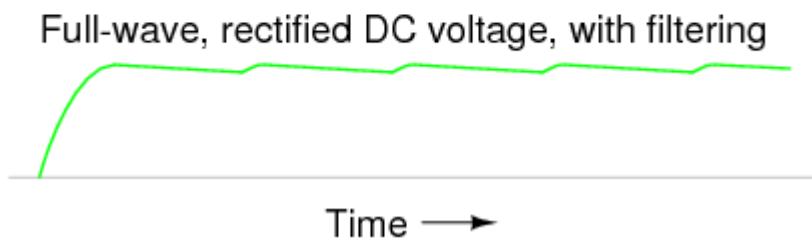
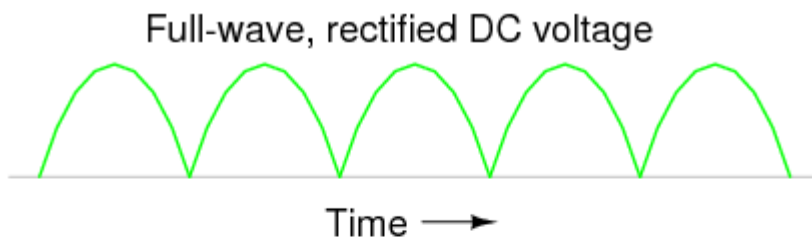

## (c) Energy and potential difference in circuits

### 2.8 explain why a series or parallel circuit is more appropriate for particular applications, including domestic lighting

Series Circuit:

- one switch can turn off the components on and off together
- if one bulb ( or other component) breaks, it causes a gap in the circuit and all of the other bulbs will go off
- the voltage supplied by the cell or mains supply is “shared” between all the components, so the more bulbs you add to a series circuit the dimmer they all become. The larger the resistance of the component, the bigger its “share of voltage”

Parallel Circuit:

- switches can be placed in different parts of the circuit to switch each bulb on and off individually or all together
- if one bulb (or other components) breaks, only the bulbs on the same branch of the circuit will be affected
- each branch of the circuit receives the same voltage, so if more bulbs are added to a circuit in the parallel they all stay bright.

Decorative lights are usually wired in series. Each bulb only needs a low voltage, so even when the voltage from the mains supply is shared between them, each bulb still gets enough energy to produce light. If one of the bulbs is not in its holder properly, the circuit is not complete and none of the bulbs will be on. In the past, if the filament in one of the bulbs broke, all of the other bulbs would go out. Today, many bulbs used in decorative lights are provided with a ‘shunt’ which allows current to continue to flow through the bulb even after the filament has broken.

The lights in our house are wired in parallel. Each bulb can be switched on and off separately and the brightness of the bulbs does not change. If one bulb breaks or is removed, you can still use the other lights.



## 2.9 understand that the current in a series circuit depends on the applied voltage and the number and nature of other components

Series circuit: In a series circuit the current is the same in all parts. Current is not used up as it passes around a circuit.

The size of the current in a series circuit depends on the voltage supplied to it, and the number and nature of the other components in the circuit. In a circuit if more cells are attached, the current will increase as more energy is being given to the electrons. If more resistance is attached to the circuit the current will get less. But current is the same at all points in a series circuit.

Parallel circuit: In a parallel circuit, current varies with the resistance and voltage. Voltages are the same at all branches.

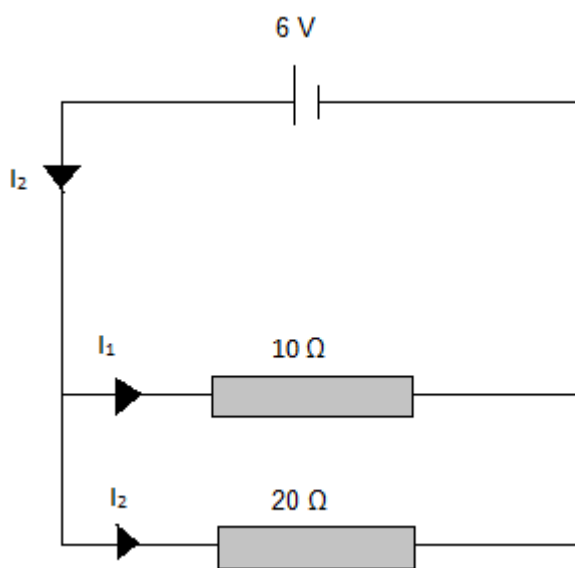

This circuit shows a 10Ω and 20Ω resistor connected in parallel to a 6V cell of negligible internal resistance. The p.d. across 10Ω and 20Ω resistors is 6V.

$$I_1 = 0.6\text{A}$$

$$I_2 = 0.3\text{A}$$

As the resistance in  $I_2$  is higher, the current is small.

$I_3 = I_1 + I_2$  The current in a parallel circuit is shared between the branches depending on the resistance.

## 2.10 describe how current varies with voltage in wires, resistors, metal filament lamps and diodes, and how this can be investigated experimentally

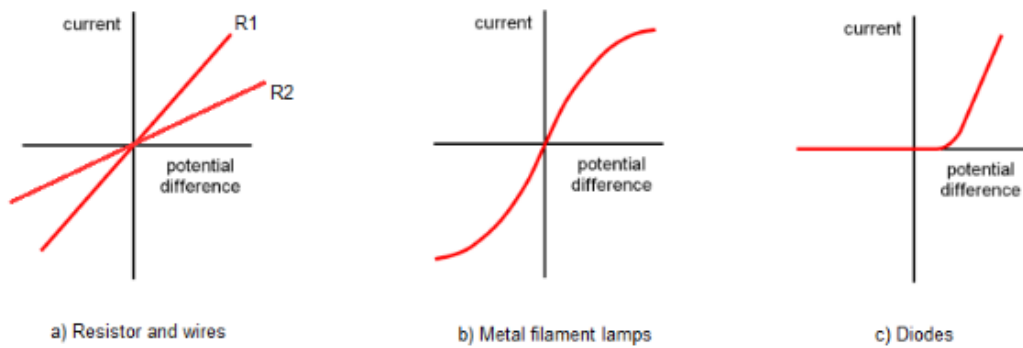

a) Resistors and wires obey Ohm's law. Current,  $I$ , is proportional to voltage,  $v$ , and the graphs are straight lines which pass through the origin (0,0) of the scales.

b) The filament in a lamp is a metal wire but it gets very hot indeed. The resistance of a metal increases with temperature - the graph curves when the lamp reaches its working current and temperature.

c) Diodes have a very large resistance when voltage is applied in the 'wrong' direction - this is shown by the horizontal line when the voltage is negative. When the voltage is in the 'right' direction (forward biased), when it reaches around  $0.7v$ , the resistance drops to a small value - the graph curves and become very steep.

### Experiment: To investigate how current varies with voltage. (Ohm's law)

The resistance of a component is related to the current through it and the voltage across it by the equation  $V = I \times R$ . If we wish to find the resistance of a component, this equation can be rearranged to give  $R = V/I$ . The circuit in Figure can be used to investigate this relationship for a piece of resistance wire.

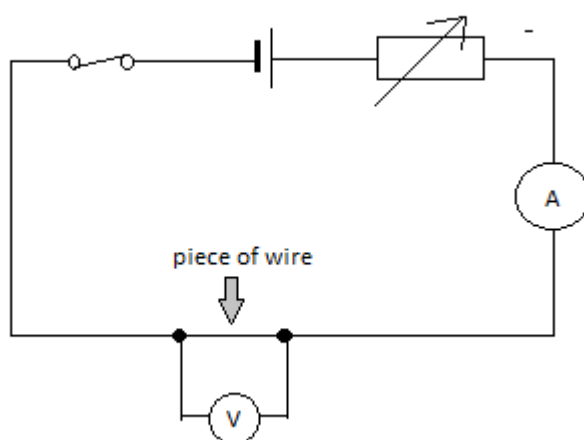

When switch  $S$  is closed for the readings on the ammeter and voltmeter are noted. The value of the variable resistor is then altered and a new pair of readings taken from the meters. The whole process

is repeated at least six times, the results are placed into a table and a graph of current against voltage is drawn.

Current, I (A)	Voltage, V (v)
0.0	0.0
0.1	0.4
0.2	0.8
0.3	1.2
0.4	1.6
0.5	2.0

The graph in Figure is a straight line passing through the origin. This tells us that the current flowing through the wire is directly proportional to the voltage applied across its end - that is, if the voltage across the wire is doubled the current flowing through it doubles.

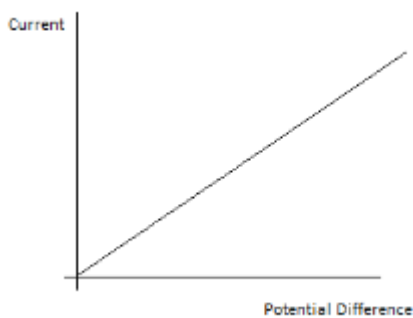

### 2.11 describe the qualitative effect of changing resistance on the current in a circuit

$$R \propto 1/I$$

Resistance is inversely proportional to current. Higher resistance means lower current and higher current means lower resistance. In other words resistance is the opposition of current. Resistance blocks charge flow.

### 2.12 describe the qualitative variation of resistance of LDRs with illumination and of



thermistors with temperature

**Light Dependant Resistors:** An LDR is a light dependant resistor. Its resistance changes with the intensity of light. In dark condition LDRs contain few free electrons and so have a high resistance. If however light is shone onto an LDR more electrons are freed and the resistance decreases. LDRs are often used in light sensitive circuits in devices such as photographic equipment, automatic lightning controls and burglar alarms.

**Thermistor:** A thermistor is a temperature dependant resistor. It is made from a semiconducting material such as silicon or germanium. At room temperature the number of free electrons is small and so the resistance of a thermistor is large. If however if it is warmed the number of the electrons increases and its resistance decreases. Thermistors are often used in temperature-sensitive circuits in



devices such as fire alarms and thermostats.

### **2.13 know that lamps and LEDs can be used to indicate the presence of a current in a circuit**

A light-emitting diode (LED) is a special kind of diode that glows when electricity passes through it. Most LEDs are made from a semi-conducting material called gallium arsenide phosphide.



LEDs can be bought in a range of colours. They can also be bought in forms that will switch between two colours (bi-colour), three colours (tri-colour) or emit infra-red light.

In common with all diodes, the LED will only allow current to pass in one direction. The cathode is normally indicated by a flat side on the casing and the anode is normally indicated by a slightly longer leg. The current required to power an LED is usually around 20 mA.

### **2.14 know and use the relationship between voltage, current and resistance:**

voltage = current × resistance

$$V = I \times R$$

### 2.15 understand that current is the rate of flow of charge

The size of an electric current indicates the rate at which charge flows. Charge(Q) is measured in coulombs (C). Current is measured in amperes (A). If 1 C of charge flows along a wire every second the current passing the wire is 1A.

### 2.16 know and use the relationship between charge, current and time:

charge = current  $\times$  time

$$Q = I \times t$$

### 2.17 know that electric current in solid metallic conductors is a flow of negatively charged electrons

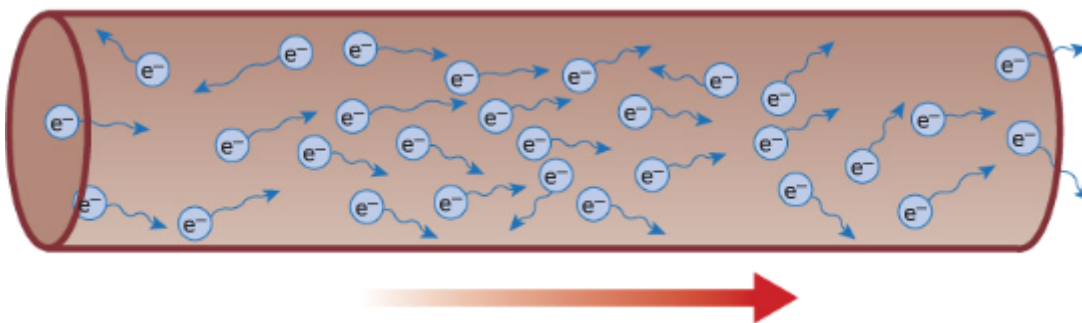

Current is the flow of charge. One coulomb of charge is equivalent of the charge carried by approximately six million, million, million ( $6 \times 10^{18}$ ) negative electrons.

### Charge direction when connected to a battery

In conductors some electrons are free to drift. But the number of electrons flowing in any one direction is roughly equal to the number flowing in the opposite direction. There is therefore no overall flow of charge. However, if a cell or battery is connected across the conductor, more of the electrons now flow in the direction away from the negative terminal and towards the positive terminal, than in the opposite direction. There is now a net flow of charge.

Electrons/charges move from the negative terminal to positive. But when you are dealing with topics such as circuit and motors, it is still considered that current flow from positive to negative. This is called conventional current.

### 2.18 understand that:

- **voltage is the energy transferred per unit charge passed**
- **the volt is a joule per coulomb.**

As the charges flow around a circuit, the energy they carry is converted into other forms of energy by the components they pass through. The voltage across each component tells us how much energy it is converting. If the voltage across a component is 1v, this means that the component is changing 1J of electrical energy into a different kind of energy each time 1C of charge passes through it.

d) Electric charge

2.19 identify common materials which are electrical conductors or insulators, including metals and plastics

Conductors: Electrical conductors are materials that allow current to pass through them. Conductors have free electron diffusion to pass current. Metals like copper, silver, aluminium have free electrons and can conduct electricity.

Insulators: Insulators do not conduct electricity because they don't have free electrons. Examples of insulators are plastics, rubber, wood etc.

## 2.20 describe experiments to investigate how insulating materials can be charged by friction

### Experiment: To investigate how insulating materials can be charged by friction

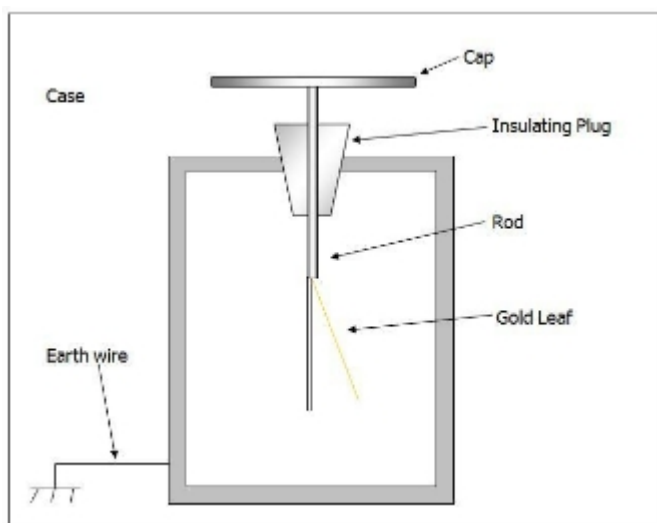

Apparatus: Glass rod, silk cloth, electroscope

Procedure:

1. Take a glass rod and silk cloth.
2. Rub the rod with the cloth.
3. Now, take any of the two materials near the metal plate of an electroscope.

Observation

1. You will notice that the leaf below will deflect.
2. This will prove that charge can be produced by friction.

## 2.21 explain that positive and negative electrostatic charges are produced on materials by the loss and gain of electrons

If two materials are rubbed together electrons will be transferred. The one that gains electrons will be negatively charged and the one that loses electrons will be positively charged.

Materials	Positive charge	Negative charge
-----------	-----------------	-----------------

Glass rod rubbed with silk	glass	Silk
Ebonite rod rubbed with fur	fur	ebonite
Perspex ruler rubbed with woolen	Perspex	Duster
Plastic comb rubbed with hair	hair	Plastic comb
Polythene strip rubbed with woolen duster	duster	Polythene
Cellulose acetate rubbed with woolen duster	acetate	duster

**2.22 understand that there are forces of attraction between unlike charges and forces of repulsion between like charges**

Similar charges repel each other and unlike charges attract each other. The attraction and repulsion occurs because of electrostatic force.

**Experiment: To investigate unlike charge attracts**

Apparatus:

- Two pieces of glass rods.
- One piece of silk cloth
- Insulating thread.

Diagram:

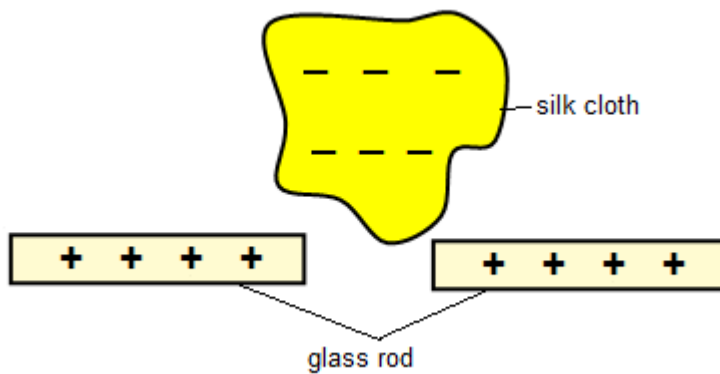

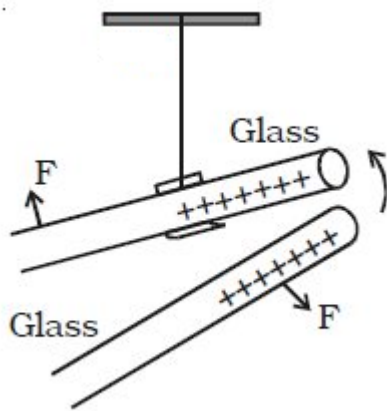

Procedure:

1. Two glass rods are rubbed by silk cloth. The rods become positively charged and the cloth becomes negatively charged.
2. One positive charged glass rod is hung by an insulating thread.
3. Another positively charged glass rod is approached towards the hung rod.

Observation:

We will see that the hung rod move away.

Conclusion:

Like charges repels.

### **Experiment: To investigate that like charge repels.**

Apparatus:

- One piece of glass rod
- One piece of ebonite rod
- Two pieces of silk rod
- Insulating thread.

Diagram:



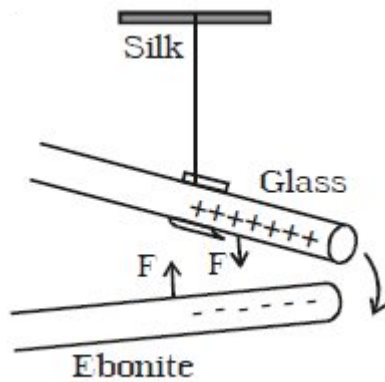
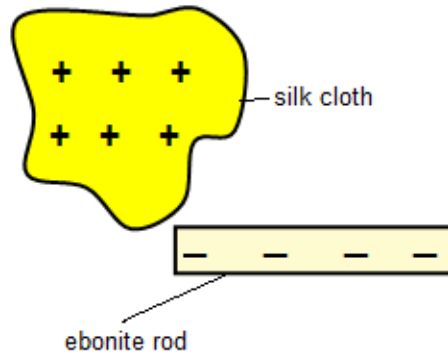
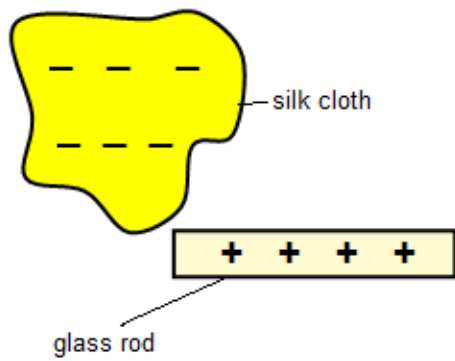

Procedure:

1. Two silk clothes are taken. When the glass rod is rubbed with the silk cloth, the glass rod becomes positively charged. Again, when with another silk cloth, the ebonite rod is rubbed, it becomes negatively charged.
2. The positively charged glass rod is hung by an insulating thread.
3. The negatively charged ebonite rod is approached towards the hung rod.

Observation:

We will see the hung rod moves towards the glass rod.

Conclusion:

Unlike charges attract.

### **Experiment: Showing that a charged object can attract an uncharged object**

If you charge a balloon by rubbing it against your jumper or your hair and then hold the balloon against a wall, you will find that the balloon sticks to the wall. There is an attraction between the charged balloon and the uncharged wall.

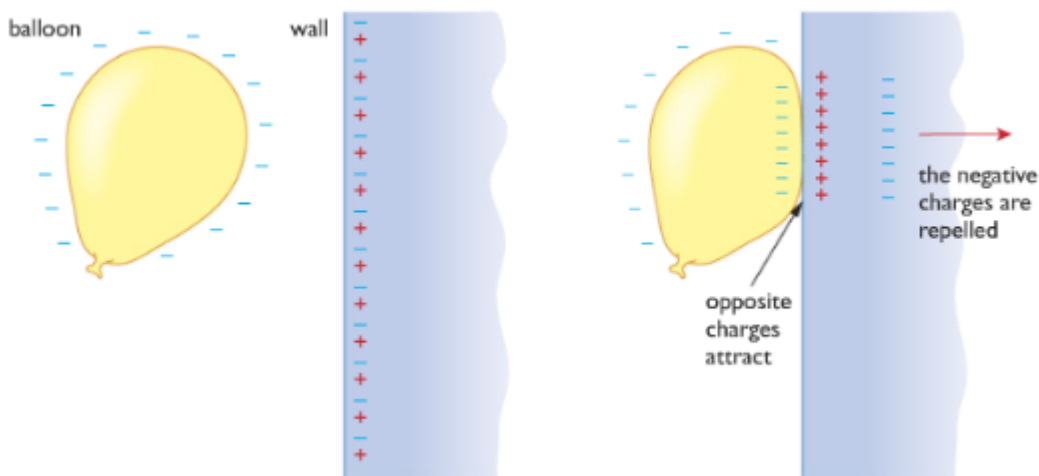

After the balloon has been charged with static electricity, but before it is brought close to the wall, the charges will be distributed. The balloon is negatively charged and the wall is uncharged – that is, the equal numbers of positive and negative charges.

As the negatively charged balloon is brought closer to the wall some of the negative electrons are repelled from the surface of the wall. This gives the surface of the wall a slight positive charge that attracts the negatively charged balloon.

### 2.23 explain electrostatic phenomena in terms of the movement of electrons

An electrostatic phenomenon is an event where electricity has a special effect, for example a static shock. Electrons move from one material to another. Materials with a negative charge will look for some way to earth like clouds through lightning.

### 2.24 explain the potential dangers of electrostatic charges, eg when fuelling aircraft and tankers

In some situations the presence of static electricity can be a disadvantage.

- As aircraft fly through the air, they can become charged with static electricity. As the charge on an aircraft increases so too does the potential difference between it and earth. With high potential differences there is the possibility of charges escaping to the earth as a spark during refueling, which could cause an explosion. The solution to this problem is to earth the plane with a conductor as soon as it lands and before refueling commences. Fuel tankers that transport fuel on roads must also be earthed before any fuel is transferred to prevent sparks causing a fire or explosion.
- Television screens and computer monitors become charged with static electricity as they are used. The charges attract light uncharged particles—that is dust.
- Our clothing can, under certain circumstances become charged with static electricity. When we remove the clothes there is the possibility of receiving a small electric shock as the charges escape to the earth.
- Workers handling electronic components must take care not to become charged by static as this can easily destroy expensive components. They wear earthing straps and work on earthed metal benches to prevent this.

### 2.25 explain some uses of electrostatic charges, eg in photocopiers and inkjet printers.

Electrostatic charges can be used in electrostatic paint spraying, inkjet printers, photocopiers, electrostatic precipitators etc.

### Electrostatic paint spraying

Painting an awkwardly shaped object such as bicycle frame with a spray can be very time consuming and very wasteful of paint. Using Electrostatic spraying can be the process efficient.

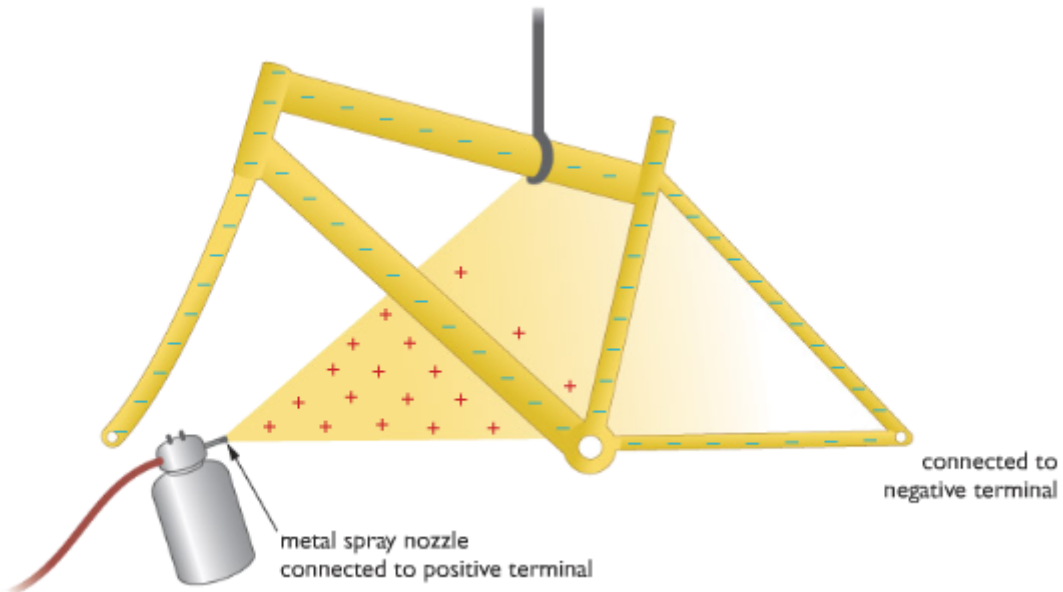

Let the metal spray nozzle be connected to a positive terminal so the paint that emerges will be positive charged. The bicycle frame should be connected to a wire and it will become negatively charged. The positively charged paint will be attracted to the frame. There is the added benefit that paint is attracted into places, such as tight corners that might otherwise not receive good coating.

### Inkjet Printers

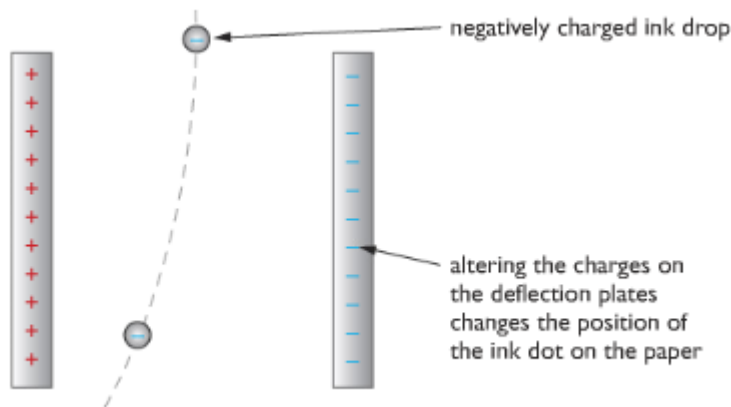

Many modern printers use inkjets to direct a fine jet of ink drops onto paper. Each spot of ink is given a charge so that as it falls between a pair of deflecting plates, electrostatic forces direct it to the correct

position. The charges on the plates change hundreds of times each second so that each drop falls in a different position, forming pictures and words on the paper as required.

### Photocopiers

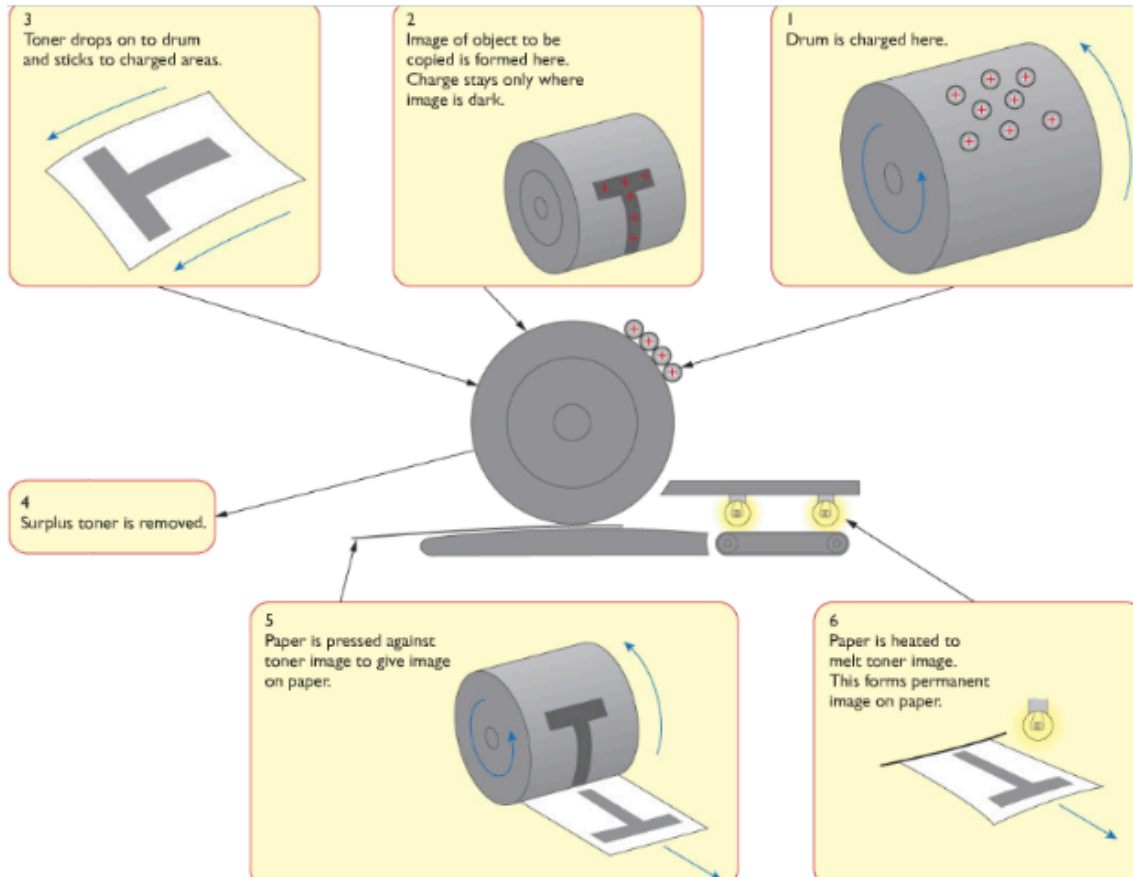

In photocopiers, the paper is shone in bright light which reflects to a rotating drum. The dark writings and pictures do not reflect. As a result the light removes the charges in the drum. Carbon powder attaches to the charges in the drum and the pictures and writings are pasted into a sheet of paper.

### Electrostatic precipitators

Many heavy industrial plants, such as steel-making furnaces and coal fired power stations, produce large quantities of smoke. This smoke carries small particles of ash and dust into the environment, causing health problems and damage to buildings. One way of removing these pollutants from the smoke is to use electrostatic precipitators.

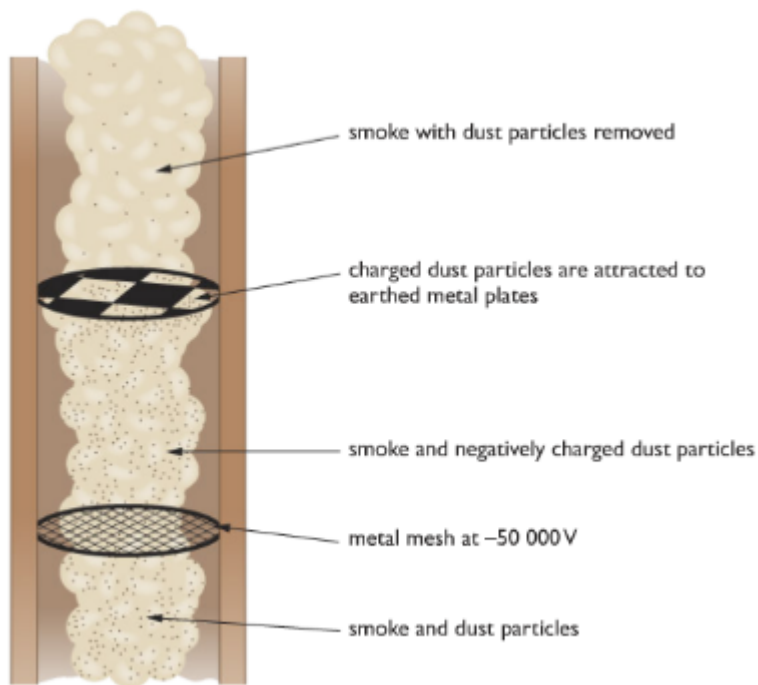

As the smoke initially rises up the chimney, it passes through a mesh of wires that are highly charged. As they pass through the mesh, the ash and dust particles become negatively charged. Higher up the chimney these charged particles are attracted by and stick to large metal earthed plates. The cleaner smoke is then released into the atmosphere. When the earthed plates are completely covered with dust and ash, they are given a sharp rap. The dust and ash fall into collection boxes, which are later emptied.

## Section 3: Waves

[[toc]]

### (a) Units

**3.1 use the following units: degree ( $^{\circ}$ ), hertz (Hz), metre (m), metre/second (m/s), second (s).**

Unit of an angle: degree ( $^{\circ}$ ) Unit of frequency: hertz (Hz) Unit of distance or wavelength: metre (m)

Unit of speed/velocity: metre/second (m/s) Unit of time-period: second (s)

### (b) Properties of waves

**3.2 understand the difference between longitudinal and transverse waves and describe experiments to show longitudinal and transverse waves in, for example, ropes, springs and water**

Waves can transfer energy and information from one place to another without transfer of matter.

Waves can be divided into two types: mechanical waves and electromagnetic waves.

Mechanical waves can be of two types: transverse and longitudinal.

**Transverse waves:** A transverse wave is one that vibrates or oscillates, at right angles to the direction in which the energy or wave is moving. Example of transverse waves include light waves and waves travelling on the surface of water.

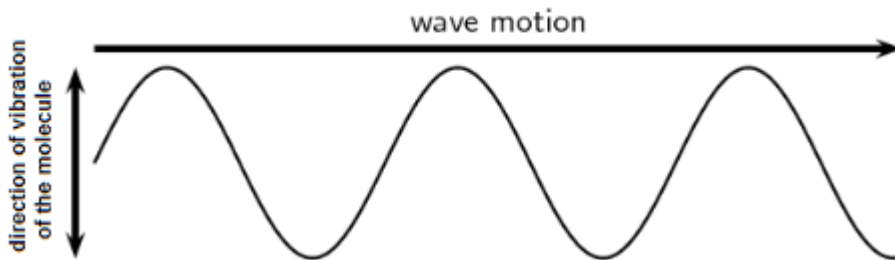

**Longitudinal waves:** A longitudinal wave is one in which the vibrations or oscillations are along the direction in which the energy or wave is moving. Examples of longitudinal waves include sound waves.

### Longitudinal Wave

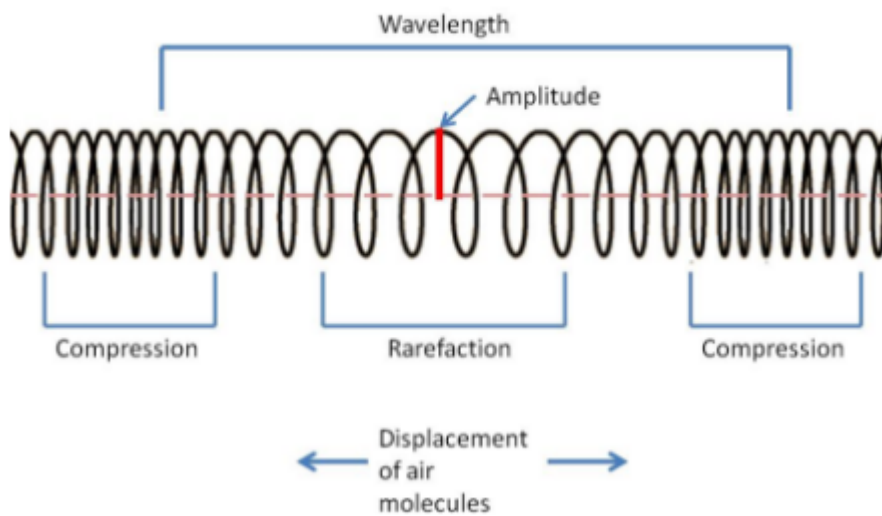

Transverse wave don't need medium to move. Longitudinal wave needs medium to move.

**Experiment: To show different types of waves in spring.**

Transverse -

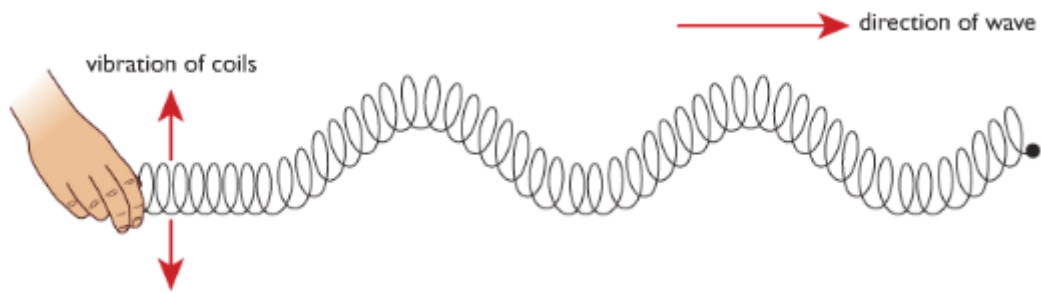

If you waggle on end of a slinky spring from side to side you will see waves travelling through it. The energy carried by these waves moves along the slinky from one end to the other, but if you look closely you can see that the coils of the slinky are vibrating across the direction in which the energy is moving. This is an example of transverse wave.

Longitudinal -

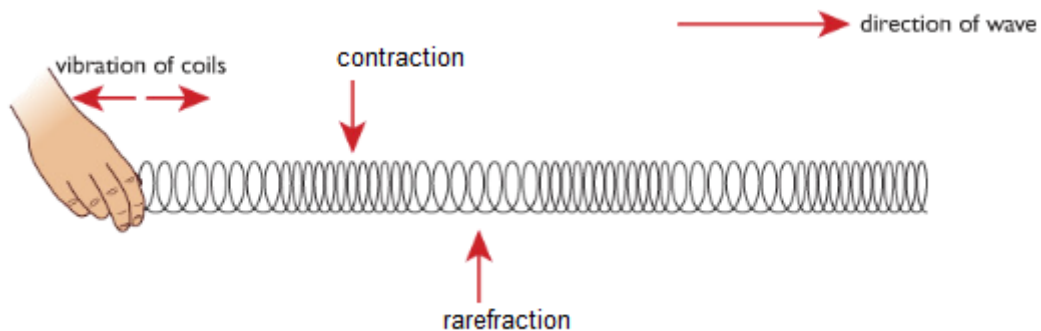

If you push and pull the end of a slinky in a direction parallel to its axis, you can see energy travelling along it. This time however the coil of the slinky are vibrating in direction that are along its length. This is an example of longitudinal wave.

**Experiment: To create water waves using a ripple tank**

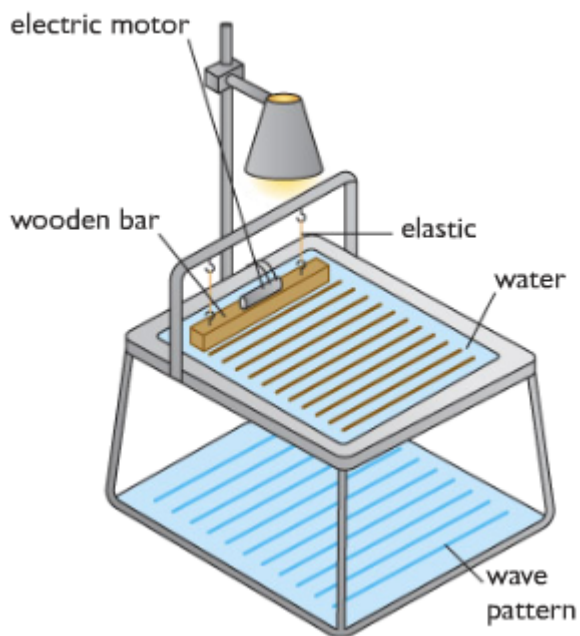

When the motor is turned on the wooden bar vibrates creating a series of ripples on the surface of water. A light placed above the tank creates pattern of the water waves on the floor. A light placed above the tank creates patterns of the water waves on the floor. By observing the patterns we can see how the water waves are behaving.

### 3.3 define amplitude, frequency, wavelength and period of a wave

**Amplitude:** Amplitude is the maximum displacement of a part of the medium from its rest position.

**Wavelength:** The distance between a particular point on a wave and the same point on the next wave (for example, from crest to crest) is called the wavelength ( $\lambda$ ).

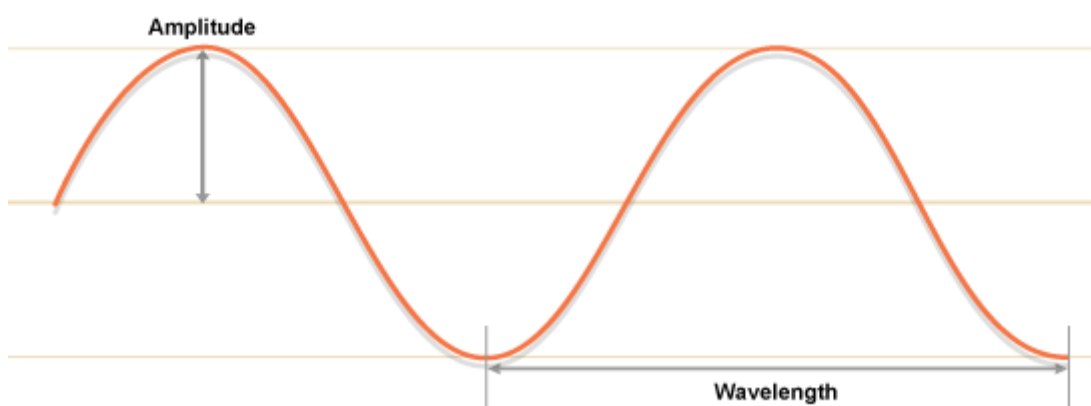

**Frequency:** The number of waves produced each second by a source, or the number passing a particular point each second is called frequency ( $f$ ).

**Period:** The period of a wave is the time for one complete cycle of the waveform.



### Experiment: Adjusting ripple tank to investigate wavelength and frequency

The motor can be adjusted to produce a small number of waves each second. The frequency of the waves is small and the pattern shows that the waves have a long wavelength.

At higher frequencies, the water waves have shorter wavelengths. The speed of the waves does not change.

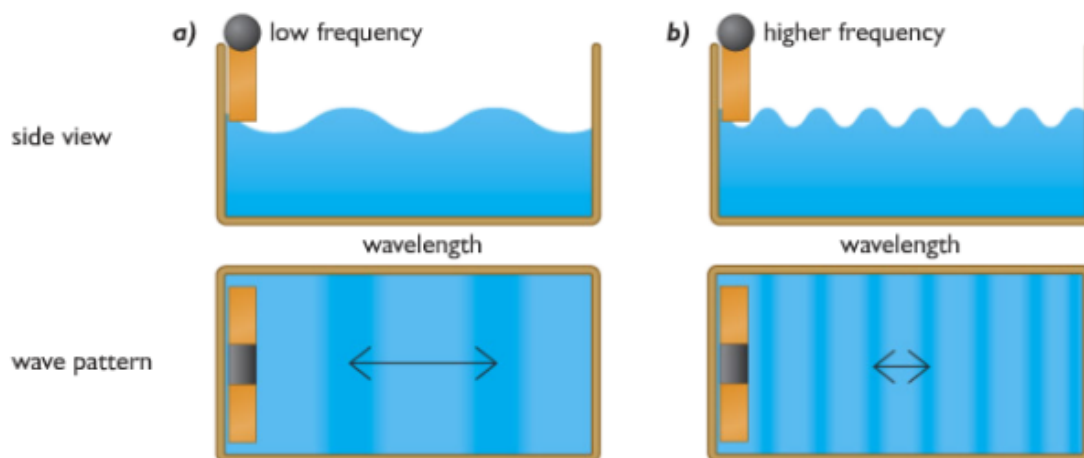

### Experiment: Demonstrating refraction using ripple tank

Refraction, the bending of light waves as they pass from one material to another, can be demonstrated by reducing the depth of water in the ripple tank (with a transparent glass or plastic sheet). Ripples travel more slowly if the depth of the water in the ripple tank is smaller. When setting up a ripple tank it is therefore important that the tank is level. Another problem with ripple tanks is unwanted reflection from the sides of the tank; these result in pretty patterns but make analysts of what you see very difficult. Most ripple tanks have sloping sides to reduce unwanted reflections.

### Experiment: To demonstrate diffraction using vibrating bar

To show the interesting effects of diffraction you need to set up continuous plane wavefronts and (circular wavefronts respectively). This is done with a vibrating bar placed wither directly in contact with the water or with two dippers just touched the water for circular wavefronts. The frequency of vibration is controlled frequency of the waves is controlled by varying the speed of electric motor attached to the beam.

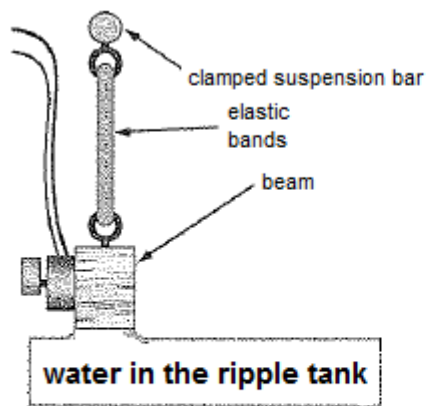

side view: Showing beam with motor to make it vibrate up and down to make plane wavefronts

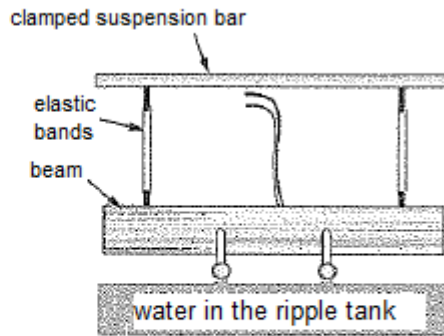

front view: Showing beam with two dippers fitted to create two sets of circular wavefronts. The beam has been raised clear of the surface.

### 3.4 understand that waves transfer energy and information without transferring matter

Waves are means of transferring energy and information from place to place. These transfers take place with no matter being transferred. Mobile phones, satellites etc. rely on waves.

Example: If you drop a large stone into a pond, waves will be produced. The waves spread out from the point of impact, carrying to all parts of the pond. But the water in the pond does not move from the centre to the edges.

### 3.5 know and use the relationship between the speed, frequency and wavelength of a wave:

wave speed = frequency  $\times$  wavelength

$$v = f \times \lambda$$

### 3.6 use the relationship between frequency and time period

frequency,  $f$  in hertz =  $1$  time period,  $T$  (in seconds)

$$f = 1/T$$

### 3.7 use the above relationships in different contexts including sound waves and electromagnetic waves

As all wave share properties the above relations can be used for any type of wave.

P - 1: The period of a wave is 0.01 second. What is its frequency?

$$\text{Ans: Frequency} = 1/T = 1/0.01\text{s} = 100 \text{ Hz}$$

P - 2: The frequency of a wave is 250 Hz and the wavelength is 0.02m. What is speed of the wave?

$$\text{Ans: } v = f\lambda = 250 \text{ Hz} \times 0.02\text{s} = 5 \text{ m/s}$$

### 3.8 understand that waves can be diffracted when they pass an edge

Diffraction is the slight bending of waves as it passes around the edge of an object. The amount of bending depends on the relative size of the wavelength of light to the size of the opening. If the opening is much larger than the wave's wavelength, the bending will be almost unnoticeable. However, if the two are closer in size or equal, the amount of bending is considerable.

**3.9 understand that waves can be diffracted through gaps, and that the extent of diffraction depends on the wavelength and the physical dimension of the gap.**

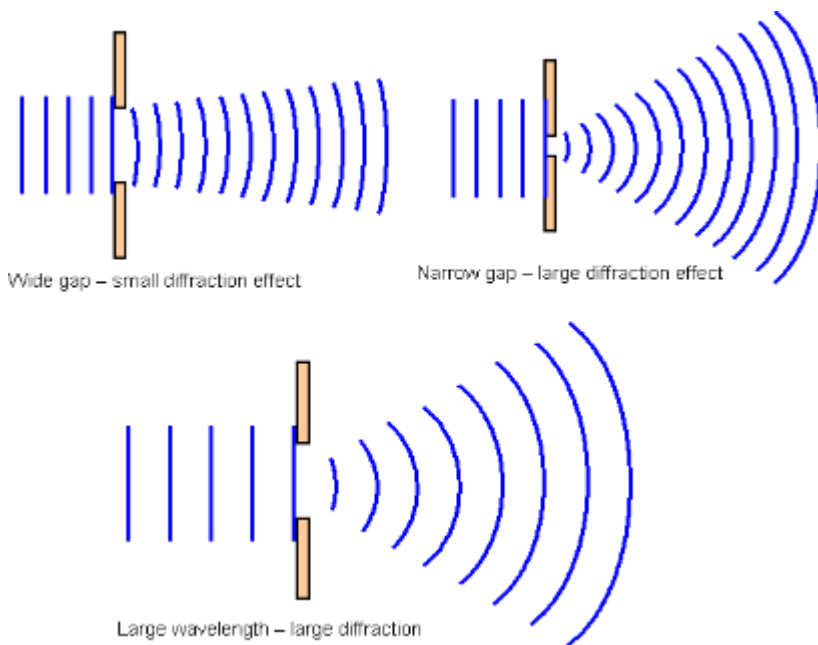

Diffraction involves a change in direction of waves as they pass through an opening or around a barrier in their path. Water waves have the ability to travel around corners, around obstacles and through openings. This ability is most obvious for water waves with longer wavelengths. Diffraction can be demonstrated by placing small barriers and obstacles in a ripple tank and observing the path of the water waves as they encounter the obstacles. The waves are seen to pass around the barrier into the regions behind it; subsequently the water behind the barrier is disturbed. The amount of diffraction (the sharpness of the bending) increases with increasing wavelength and decreases with decreasing wavelength. In fact, when the wavelength of the waves is smaller than the obstacle, no noticeable diffraction occurs.

## (c) The electromagnetic spectrum

**3.10 understand that light is part of a continuous electromagnetic spectrum which includes radio, microwave, infrared, visible, ultraviolet, x-ray and gamma ray radiations and that all these waves travel at the same speed in free space**

The electromagnetic spectrum is a continuous spectrum of waves which includes the visible spectrum.

1. they all transfer energy
2. they are all transverse waves
3. they all travel at speed of light in vacuum ( $3 \times 10^8$  m/s)
4. they can all be reflected, refracted and diffracted

**3.11 identify the order of the electromagnetic spectrum in terms of decreasing wavelength and increasing frequency, including the colours of the visible spectrum**

Different frequencies and wavelength differ them into different groups and consequently have different properties. Radio waves have the lowest frequency and the longest wavelength. Gamma rays have the highest frequency and the shortest wavelength.

	Typical frequency(hz)	Typical wavelength (m)
Radio Waves	$10^5-10^{10}$	$10^3-10^{-2}$
Microwaves	$10^{10}-10^{11}$	$10^{-2}-10^{-3}$
Infra-red	$10^{11}-10^{14}$	$10^{-3}-10^{-6}$
Visible light	$10^{14}-10^{15}$	$10^{-6}-10^{-7}$
Ultraviolet	$10^{15}-10^{16}$	$10^{-7}-10^{-8}$
X-rays	$10^{16}-10^{18}$	$10^{-8}-10^{-10}$
Gamma rays	$10^{18}-10^{21}$	$10^{-10}-10^{-14}$

A mnemonic can help: **R**un **M**iles **I**n **V**ery **U**npleasant **eX**treme **G**ames.

**Colours of the visible spectrum**

There are seven colours in the visible spectrum: red, orange, yellow, green, blue, indigo and violet. Red has the longest wavelength and lowest frequency.

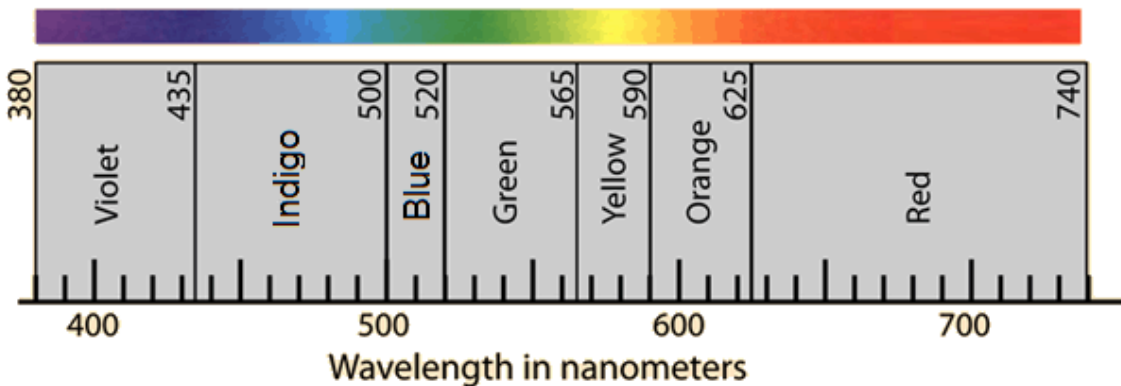

A mnemonic can help: **R**ichard **O**f **Y**ork **G**ave **B**attle **I**n **V**ain

The EM spectrum is continuous - it is only broken up into distinct zones for convenience. For example, the visible light spectrum is made up of an indeterminate number of colours that blend smoothly from one shade to the next.

**3.12 explain some of the uses of electromagnetic radiations, including:**

**Radio waves:** It is used in communicating information. This can be speech, radio and television, music and encoded messages like computer data, navigation signals and telephone conversations. The properties that make radio waves suitable for communicating are:

- Radio waves can travel quickly.
- Can code information.
- Can travel long distance through buildings and walls.
- It is not harmful.

**Microwaves:** Microwaves are used in microwave oven which cooks food more quickly than in normal oven. Microwaves are also used in communications. The waves pass easily through the Earth's atmosphere and so are used to carry signals to orbiting satellites. From here, the signals are passed on to their destination. Messages sent to and from mobile phones and radar are also carried by microwaves.

**Infrared:** Special cameras designed to detect infra-red waves can be used to create image even in the absence of visible light. The image can be created because of the different temperatures of objects. Wavelength of infrared from warm objects is shorter than the infrared from cool objects. Infra-red radiation is also used in remote controls for televisions, videos and stereo systems. Moreover it is used in heating materials like heater.

**Visible light:** The main use of visible light is to see. Visible light from lasers is used to read compact discs and barcodes. It can also be sent along optical fibres, so it can be used for communication or for looking into inaccessible places such as inside of the human body. Furthermore, it has uses in photography too.

**Ultraviolet:** Some chemicals glow when exposed to UV light. This property of UV light is used in security markers. The special ink is invisible in normal lights but becomes visible in UV light. UV light is also used in fluorescent lamps, to kill bacteria, to harden fillings and disco 'black' lights. Some insects can see into the ultraviolet part of spectrum and use this to navigate and to identify food sources.

**X-rays:** X-ray is used to take pictures of patient's bone to determine any fracture. X-rays are also used in industry to check the internal structures of objects-for example: to look for cracks and faults in buildings or machinery- and at airport as part of the security checking procedure. The X-rays produced by collapsing stars are also used in radio astronomy.

**Gamma rays:** They are used to sterilise medical instruments, to kill micro-organisms so that food will keep for longer and to treat cancer using radiotherapy.

### **3.13 understand the detrimental effects of excessive exposure of the human body to electromagnetic waves, including:**

and describe simple protective measures against the risks.

**Microwaves:** Micro waves might cause internal heating of body tissue. For this microwave ovens have metal screens that reflect microwaves and keep them inside the oven. It also has perceived risk of cancer.

It can be prevented by closing oven doors and using hands-free cell phones.

**Infrared:** The human body can be harmed by too much exposure to infra-red radiation, which can cause skin burning and cell damage.

It can be prevented by avoiding hot places, using reflective clothing and avoiding exposure to sun.

**Visible light:** Visible light can cause eye damage.

It can be prevented by sun glasses and avoiding exposure to the sun.

**Ultraviolet:** Overexposure of ultraviolet light will lead to sunburn and blistering. This can also cause skin cancer, blindness and damage to surface cells.

Protective goggles or glasses and skin creams can block the UV rays and will reduce the harmful effects of this radiation.

**X-rays:** X-ray has risk of cancer and cell damage.

Lead shielding, Monitor exposure (film badge), protective clothing can be used to prevent the risk.

**Gamma rays:** Gamma rays can damage to living cells. The damage can cause mutations in genes and can lead to cancer.

Lead shielding, Monitor exposure (film badge) can be used to prevent the risk.

## (d) Light and sound

### 3.14 understand that light waves are transverse waves which can be reflected, refracted and diffracted

Light waves are transverse wave that is emitted from luminous (objects that emit their own light such as sun, stars, fires, light bulbs etc.) or reflected from non-luminous objects (objects which do not emit their own light but are seen by their reflection of light). Light waves are transverse wave and like all waves, they can be reflected, refracted and diffracted.

### 3.15 use the law of reflection (the angle of incidence equals the angle of reflection)

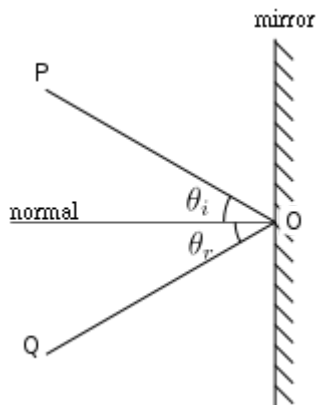

The law of reflection states that:

1. The incident ray, reflected ray and normal all lie in the same plane.
2. The angle of incidence ( $\theta_i$ ) is equal to the angle of reflection ( $\theta_r$ ).

### Experiment: To illustrate the laws of reflection.

**Apparatus:** Ray box, strip of plane mirror, protractor, piece of paper.

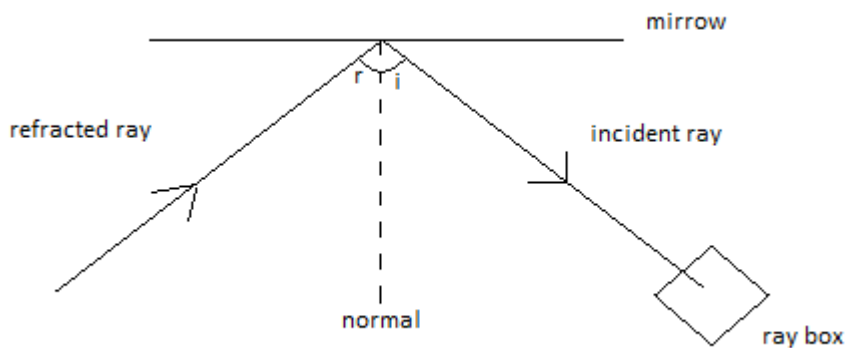

**Procedure:**

1. Set up the apparatus as shown in Figure.
2. Vary the angle of incidence  $i$  and measure the angle of reflection  $r$ .
3. Compare the values of  $i$  and  $r$ .

**3.16 construct ray diagrams to illustrate the formation of a virtual image in a plane mirror**

Types of images:

1. Virtual images: Image through which the rays of light don't actually pass is called virtual image. Example: Image formed in the mirror. Virtual images cannot be produced on a screen.
2. Real images: Images created with rays of light actually passing through them are called real images. Example: cinema screen.

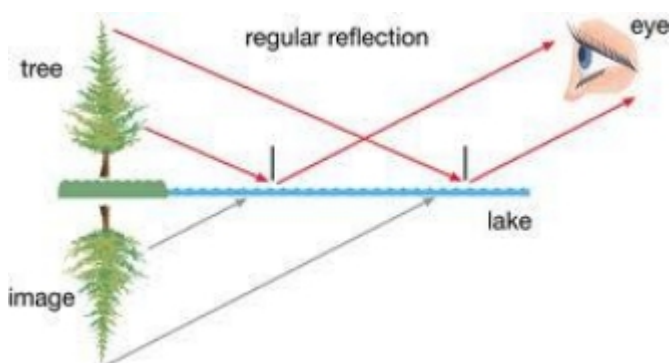

*Fig. Reflection of a tree. How the virtual image looks like below the lake.*

Properties of an image in a plane mirror:

- The image is as far behind the mirror as the object is in front
- The image is the same size as the object
- The image is virtual as it appears to be behind the mirror. The rays of light are not actually coming from the place where the image seems to be.
- The image is laterally inverted - that is, the left side and right side of the image appear to be interchanged.

How to construct ray diagrams?

Things we include in ray diagrams of a plain mirror:

i- Object ii-Observer's eye or some indication iii- Plane mirror iv- Image.

1- Have object in front of the mirror.

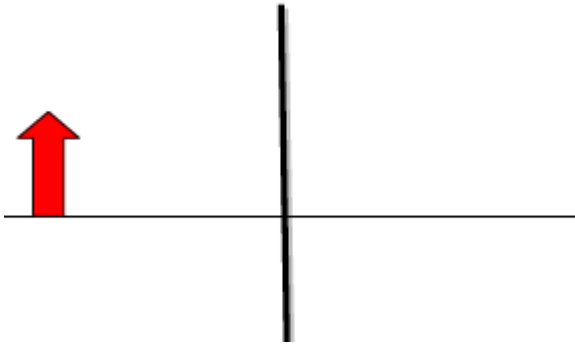

2- Draw atleast two rays emanating from the object (one from the top of the object and other at the bottom as shown below) and going towards mirror-- for some objects we need three or more.

3- Reflect ray from the mirror by using law of reflection towards observer.

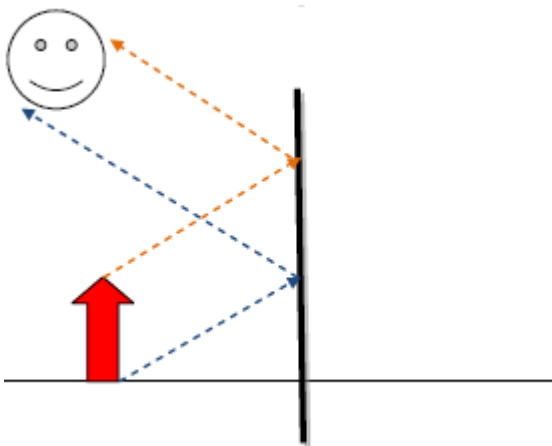

4- Extend the rays by dotted lines behind the mirror.

5- Construct the image according to the position of the ray ie if ray is coming from the bottom side of the object then it would show the bottom side and so and so as shown below.



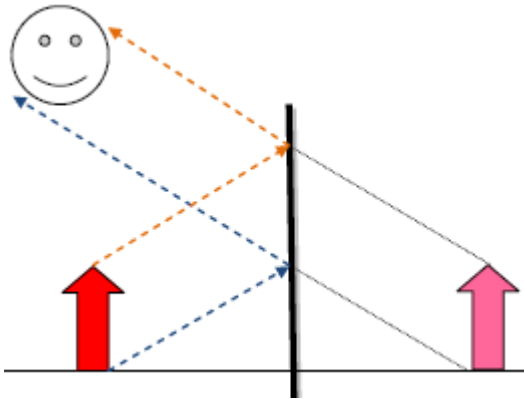

### **3.17 describe experiments to investigate the refraction of light, using rectangular blocks, semicircular blocks and triangular prisms**

As a light ray passes from one transparent medium to another, it bends. This bending of light is called refraction. Refraction occurs due to having different speed of light in different medium. For example, light travels slower in glass than in air. When ray of light travels from air to glass, it slows down as it crosses the boundary between two media. The change in speed causes the ray to change direction and therefore refraction occurs.

The light bends towards the normal as it passes from low-density to high-density (air to glass). The light is refracted and upon emerging from the glass the light bends away from the normal as it passes high density to low-density (glass to air).

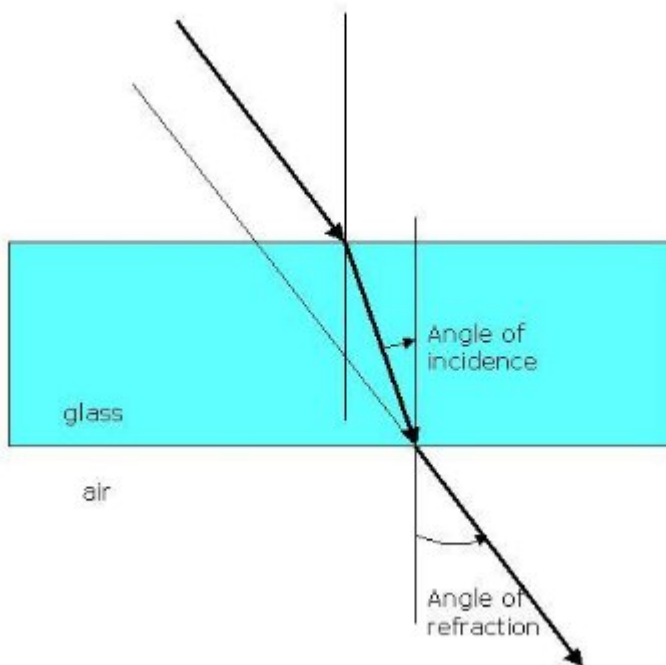

The light bends towards the normal as it passes from low-density to high-density (air to glass). The light is refracted and upon emerging from the glass the light bends away from the normal as it passes high density to low-density (glass to air).

When the ray first entered the semi-circular glass, it was along the normal. As a result, it went straight. While escaping the glass, the light bend away from the normal.

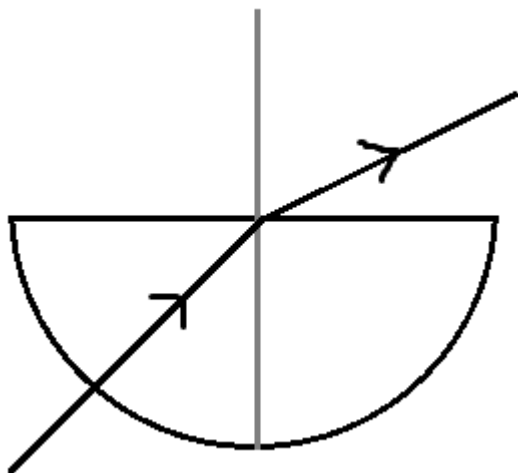

When the ray first entered the semi-circular glass, it was along the normal. As a result, it went straight. While escaping the glass, the light bend away from the normal.

The incident ray entered the prism and is refracted. This ray travels along the prism in straight line, then again refraction after leaving the prism.

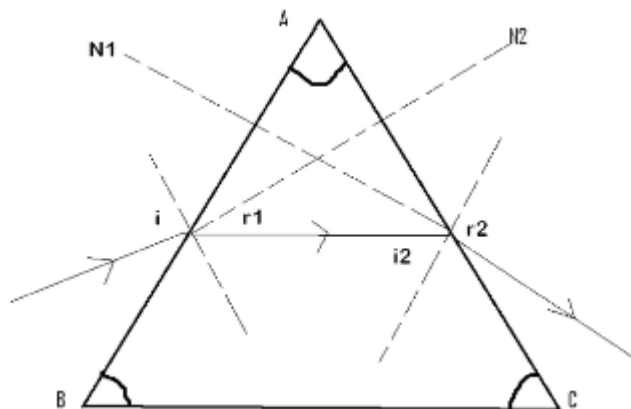

The incident ray entered the prism and is refracted. This ray travels along the prism in straight line, then again refraction after leaving the prism.

**Experiment: To demonstrate the refraction of light through a piece of glass block.**

**Apparatus:** Rectangular glass block with one face frosted, two rays boxes, piece of paper, protractor.

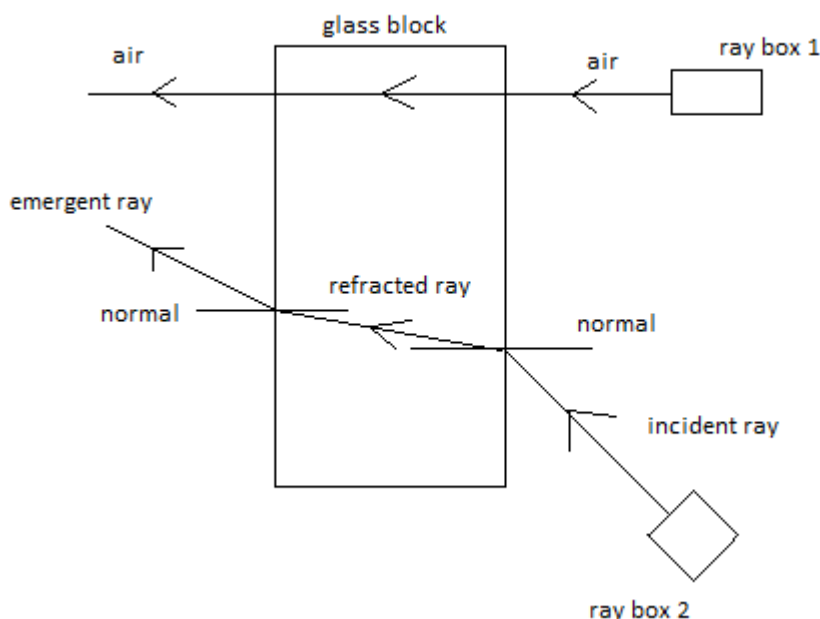

**Procedure:**

1. Place the glass block on a piece of paper with the frosted side down.
2. Send two narrow rays of light through the glass block as shown in Figure.
3. Observe the paths of the two rays of light.
4. Vary the angle of incidence  $i$  and measure the angle of refraction  $r$  using protractor\*.\*

**3.18 know and use the relationship between refractive index, angle of incidence and angle of refraction:**

The ratio between sine of the angle of incidence and the sine of the angle of refraction is called refractive index. In a material, the refractive index is constant throughout the circuit.

$$n = \frac{\sin i}{\sin r}$$

$$\text{refractive index} = \frac{\sin(\text{incident angle})}{\sin(\text{refracted angle})}$$

- Lighter mediums means that light can pass easily/ speed of light is more.
- Dense/light doesn't mean physical density rather than optical condition.
- Refraction takes place in second medium.
- The ratio from a vacuum to a denser medium is called absolute refractive index.
- The ratio from a medium to another medium is called relative refractive index.
- It doesn't have a unit because it is the ratio of same curve.
- Wavelength decreases in a denser medium, thus decreasing speed.
- The higher the wavelength, the more the light will bend.
- The higher the wavelength, the less the angle of refraction.

### 3.19 describe an experiment to determine the refractive index of glass, using a glass block

**Experiment: To determine the refractive index of glass, using a glass block.**

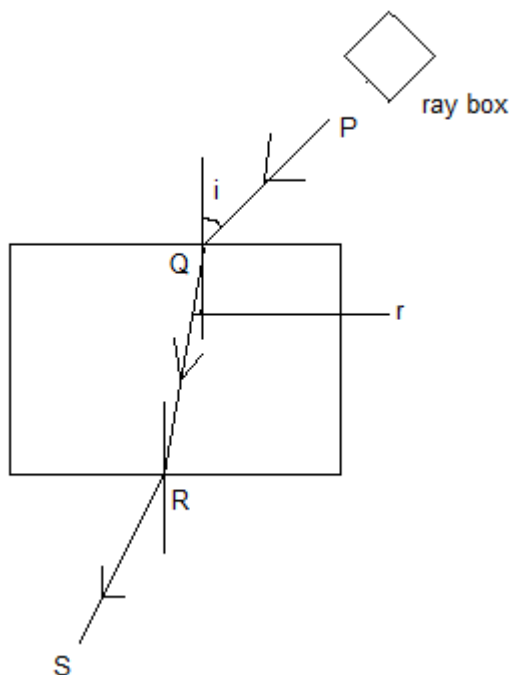

1. Put the glass block on an wooden table which is passed by a white sheet.
2. The border of the block is marked by a pencil.
3. At one border draw a normal and draw three lines to use as incident ray.
4. Set a ray box through anyone of the lines.
5. The ray travels and passes through the glass block and finally emerges from the glass block.
6. The passage of the ray is marked by putting some pins.
7. Now move the glass block and gain the footprints of the pins to show the passage of the ray.
8. Now using a protractor measure the  $\angle i$  and  $\angle r$ .
9. Now using,  $n = \frac{\sin i}{\sin r}$ ; calculate refractive index.

#### **Ways to improve result:**

1. Repeat the experiment, and find the average reading.
2. Plot a graph of  $\sin i$  against  $\sin r$  and find the gradient.
3. Vary the value of  $i$  and repeat.

### 3.20 describe the role of total internal reflection in transmitting information along optical fibres and in prisms

Total internal reflection: When light falls on the surface of a lighter medium from denser medium at an angle of incidence greater than critical angle, then the light does not refract. It rather reflects in the self-medium. This type of reflection is called total internal reflection.

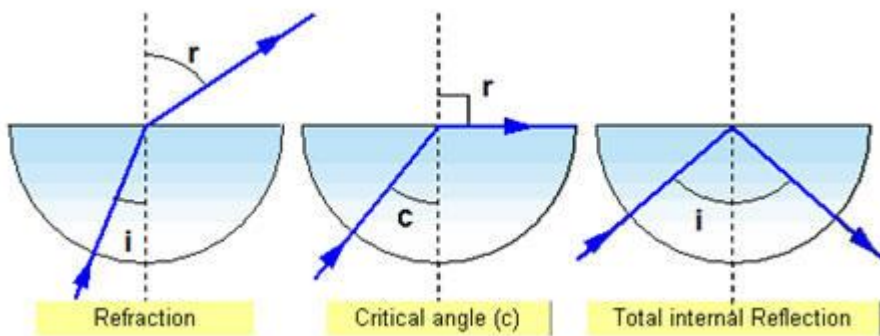

Condition of total internal reflection:

1. Light should fall in the surface of lighter medium from denser medium.
2. Angle of incidence must be greater than the critical angle.

Uses of total internal reflection:

i) The prismatic periscope

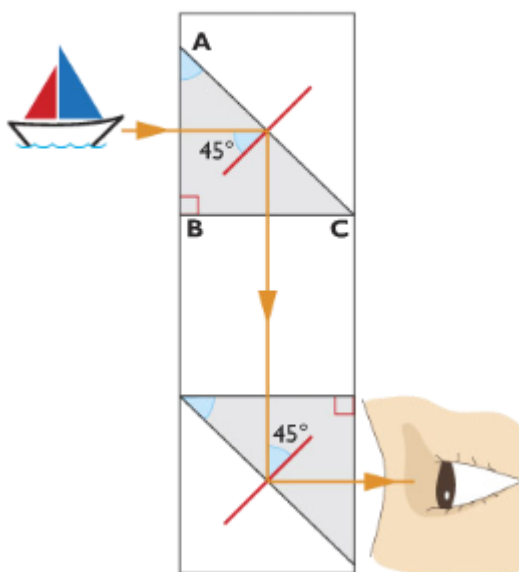

Light passes normally through the surface AB of the first prism (that is, it enters the prism at  $90^\circ$ ) and so is undeviated. It then strikes the surface AC of the prism at angle of  $45^\circ$ . The critical angle for glass is  $42^\circ$  so the ray is totally internally reflected and is turned through  $90^\circ$ . On emerging from the first prism the light travels to a second prism which is positioned such that the ray is again totally internally reflected. The ray emerges parallel to the direction in which it was originally travelling.

The final image created by this type of periscope is likely to be sharper and brighter than that produced by a periscope that uses two mirrors. Because in mirrors, multiple images are formed due to several partial internal reflections at the non-silvered glass surface of the mirror.

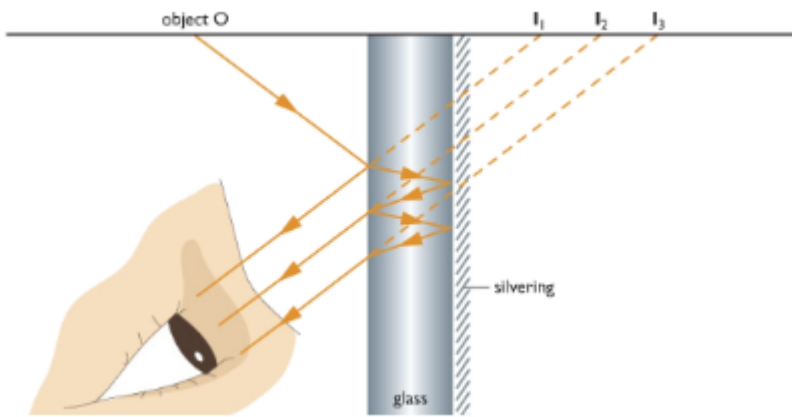

ii) Reflectors

Reflector is a block of glass that changes the direction of rays into the required position.

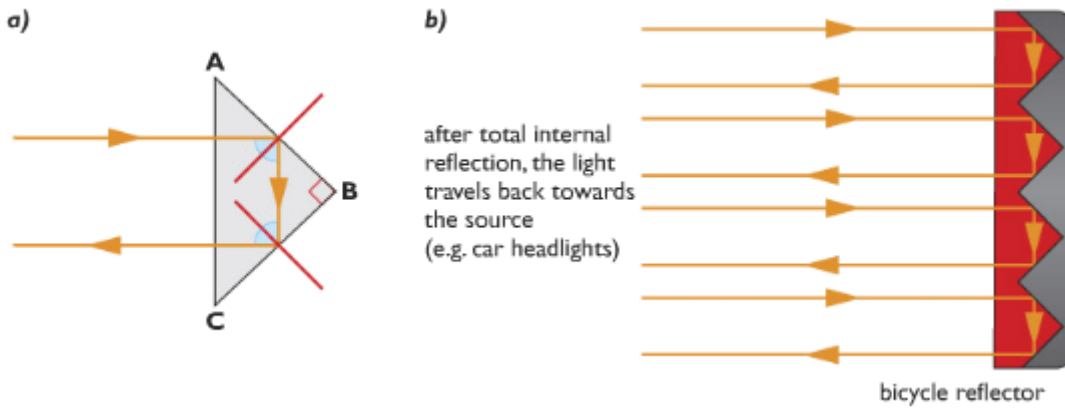

Light entering the prism undergoes total internal reflection twice. It emerges from prism travelling back in the direction from which it originally came. This arrangement is used in bicycle reflectors and binoculars.

iii) Optical fibres

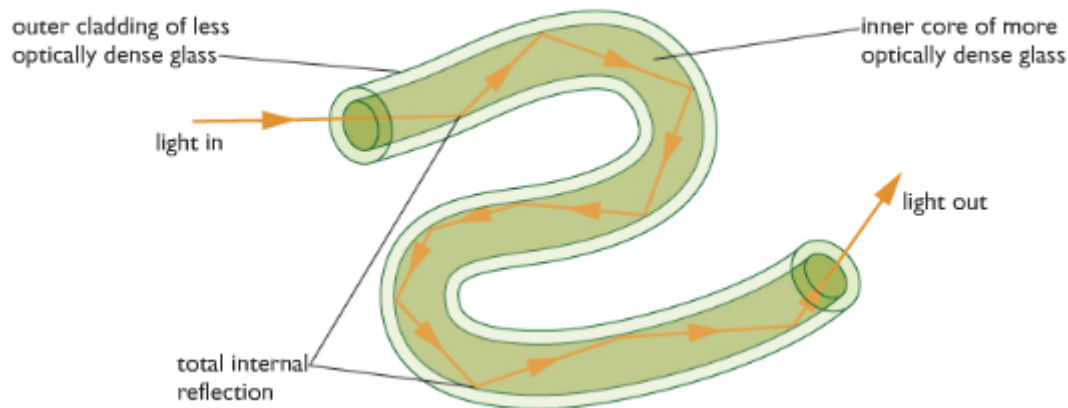

Optical fibre uses the property of total internal reflection. This is very thin strand composed of two different types of glass. The inner core is more optically dense than the outer one. As the fibres are narrow, light entering inner core always strike the boundary of the two glasses at an angle greater than critical angle. This technique is used to send information very fast at the speed of light.

Optical fibres are also used in endoscopes and telecommunications.

The endoscope is used by doctors to see inside human body. Light travels down one bundle of fibres and illuminates the object to be viewed. Light reflected by the object travels up a second bundle of fibres. An image of object is created by the eyepiece.

Modern telecommunication systems use optical fibres to transmit messages. Electrical signals from a telephone are converted into light energy by tiny lasers, which send pulses of light into the ends of optical fibres. A light-sensitive detector at the other end changes the pulses back into electrical signals, which then flow into a telephone receiver.

Optical fibres allow a much wider bandwidth. This means that many different digital signals can share the same optical fibre, so much more information can be transmitted along an optical fibre than by using an analogue signal.

Advantages of sending data using Optical Fibre:

- Optical fibre is less prone to noise.
- It is less prone to heating.
- It can send more information per second than copper wires.

### 3.21 explain the meaning of critical angle c

Critical angle is an incident angle at which the incident ray is refracted and the refracted angle is equal to 90 degree in condition that the light falls on the surface of a lighter medium from denser medium.

### 3.22 know and use the relationship between critical angle and refractive index:

$$\sin c = \frac{1}{n}$$

$$\sin(\text{critical angle}) = \frac{1}{\text{refractive index}}$$

### 3.23 understand the difference between analogue and digital signals



To send a message using a digital signal, the information is converted into a sequence of numbers called a binary code. Digital electrical signals can either have of only two possible values (typically 0v and 5v). These represent the digits 0 and 1 used in the binary number system.

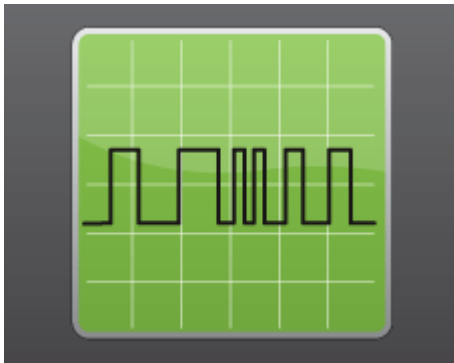

In the analogue method, the information is converted into electrical voltages and current that vary continuously.



### **3.24 describe the advantages of using digital signals rather than analogue signals**

1. Regenerating digital signal creates a clean accurate copy of the original signal but analogue signal are corrupted by other signals.
2. With digital signal, you can broadcast programs over the same frequency. It is possible because digital signals can carry more information per second than analogue signals. In analogue signal you need wider range of frequency to broadcast.
3. Digital systems are generally easier to design and build than analogue systems. That is the information can be stored and processed by computers.

### **3.25 describe how digital signals can carry more information**

Digital signals are capable of carrying more information than analogue signals because digital signals make use of the bandwidth more efficiently by closely approximating the original analogue signal. The parts of the signal that do not carry any information are thrown out thus saving the bandwidth from being used needlessly. Also, depending on the coding process, digital signals are much more efficient at filtering out noise than are analogue signals, which do not filter out noise at all thus saving even more bandwidth. The process of approximating the analogue signal in digital signal processing is called quantization.

### 3.26 understand that sound waves are longitudinal waves and how they can be reflected, refracted and diffracted

Sound waves are longitudinal waves. They are produced by vibration of objects. Like other waves they can also be reflected refracted and diffracted.

Reflection:

Sound waves reflect when they bounce back from a surface so that the angle of incident is equal to the angle of reflection. A reflected sound wave is called an echo.

Example:

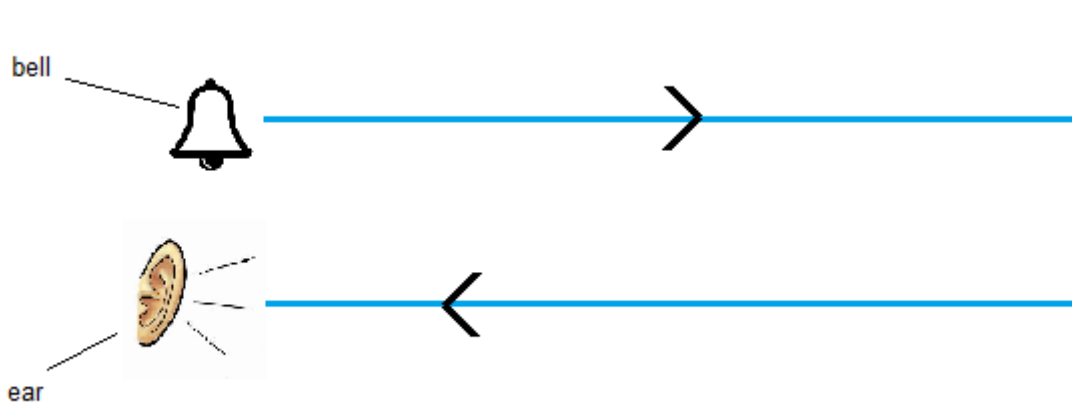

Sound is produced behind a nearby wall. After few seconds, a second sound is heard. Due to the reflection of sound wave echo is heard.

Refraction:

Sound waves refract when it changes direction while travelling across a high dense medium.

Example:

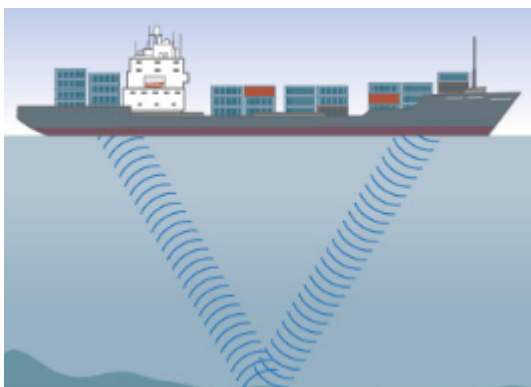

Sound wave is sent from the boat to determine the depth of the sea. It refracts when it enters into water. The return wave is received by a receiver. Measure the time required we can measure the depth of sea.

Diffraction:

Sound waves are diffracted when they spread while travelling through a narrow space such as doorway.

Example:

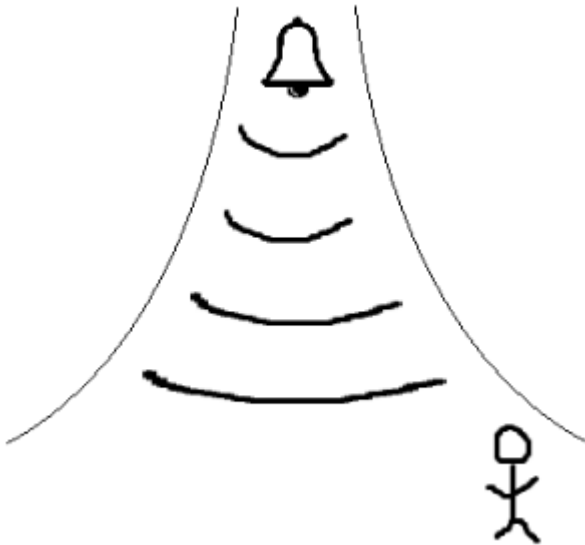

Sound is produced in the corridor. When it leaves the corridor, it diffracts. So a person standing at one side can hear the sound.

How sound wave travels?

When a vibration occurs, it pushes the air molecules around it closer together. This creates a compression. These particles then push against neighbouring particles so that the compression appears to be moving. Behind the compression is a region where the particles are spread out. This region is called rarefaction. In this way, they create compression and rarefaction and transfer energy.

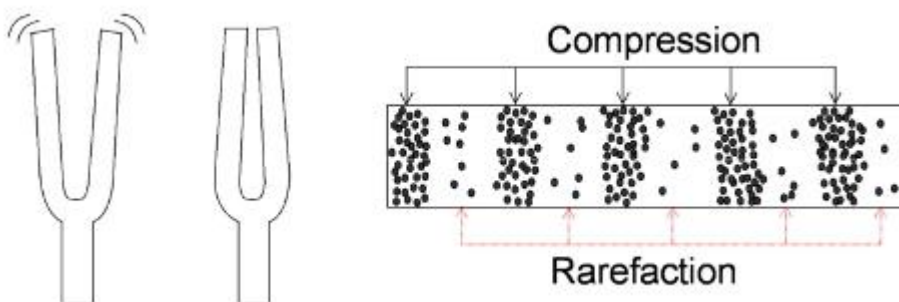

### 3.27 understand that the frequency range for human hearing is 20 Hz - 20,000 Hz

An average person can only hear sound that have a frequency higher than 20Hz but lower than 20000 Hz. This spread of frequency is called audible range. Frequency higher than 20000 Hz which cannot be

heard by humans are called ultrasounds. Frequency lower than 20 Hz that cannot be heard by humans are called infrasound.

### 3.28 describe an experiment to measure the speed of sound in air

#### Experiment: To measure the speed of sound by direct method

Apparatus: Starting pistol, stopwatch, measuring tape.

Procedure:

1. By means of measuring tape, observers are positioned at known distance apart in an open field.
2. First observer fires a starting pistol.
3. Second observer seeing the flash of the starting pistol, starts the stopwatch and then stops it when he hears the sound. The time interval is then recorded.

Ways to improve:

1. Repeat the experiment a few times and compute the values of the speed of sound for each experiment. Find the average value. This procedure minimizes random errors in finding the time interval between seeing the flash and hearing the sound.
2. Observers exchange positions and repeat experiment. This procedure will cancel the effect of wind on the speed of sound in air.

#### Experiment: To measure the speed of sound using echoes

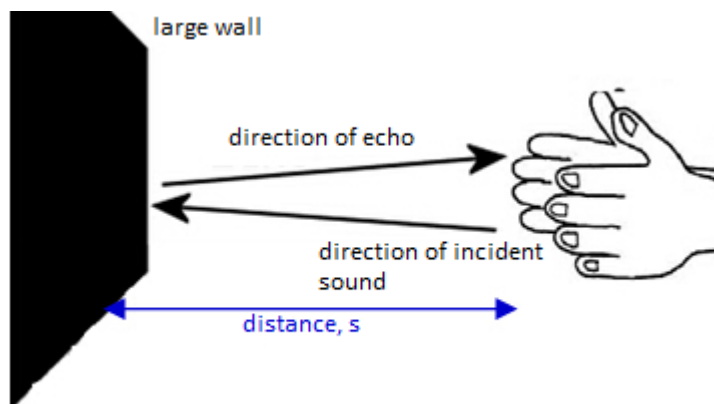

One boy claps, the sound travels and reflects from a nearby wall. After few seconds the echo is heard. Another boy starts the stopclock when the sound is produced and stopped the clock when the echo is heard. Now if the distance between the source of sound can reflector is  $d_1$  and the speed of sound will be  $v=2dt$ ; where  $t$  = time from go and back.

Sources of error:

1. Reaction time, i.e when starting the clock by hearing the echo or stopping it when receiving the echo.

Ways to improve:

1. Repeat this 5 times.
2. Make sure there are no other large reflection surfaces nearby.

### Experiment: To measure the speed of sound using resonance tubes and

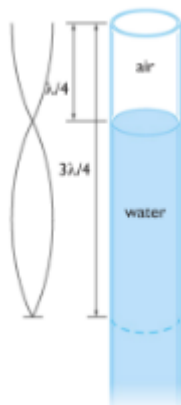

#### tuning forks

A resonance tube is a Perspex tube with a water reservoir. The height of the water in the tube can be adjusted to change the length of the tube, as the sound waves will be reflected at the water surface. A sound of a known frequency is made by striking a tuning fork and holding it above the open end of the tube. The water column is adjusted until the loudest sound can be heard. As in the figure, the first resonance will be heard when the length of the air in the tube is equal to a quarter of the wavelength. You can check your result by lowering the water level to find the next resonance, at  $\frac{3}{4}$  of the wavelength. The speed of sound is then calculated using

$$v = f \times \lambda$$

### Experiment: To measure the speed of sound using oscilloscopes



The apparatus is set up as in the figure. Set the signal generator to give a sound with frequency of about 1kHz. Start with the microphones close together, and observe how the two traces on the oscilloscope compare. Then move one microphone further away from the loudspeaker until it is one complete wavelength away from the first - you know you have arrived at this point when the traces on the oscilloscope screen are exactly above one another. Measure the distance between the microphone to get the wavelength of the sound, and use the oscilloscope screen to find an accurate value for the frequency. The speed of sound can then be worked out using the formula  $v = f \times \lambda$ .

#### 3.29 understand how an oscilloscope and microphone can be used to display a sound wave

When sound waves enter the microphone, they make a crystal or a metal plate inside it vibrate. The vibrations are changed into electrical signals, and the oscilloscope uses these to make a spot which

moves up and down on the screen. It moves the spot steadily sideways at the same time, producing a wave shape called waveform.

The waveform is really a graph showing how the air pressure at the microphone varies with time. It is not a picture of the sound waves themselves: Sound waves are not transverse (up and down).

Oscilloscopes are instruments used to show waveforms of electrical signals.

When we speak in microphone, sound waves are converted into electrical signals. When we connect the microphone to the oscilloscope then the oscilloscope would display waveforms onto the screen. The waveforms are a representation of sound waves.

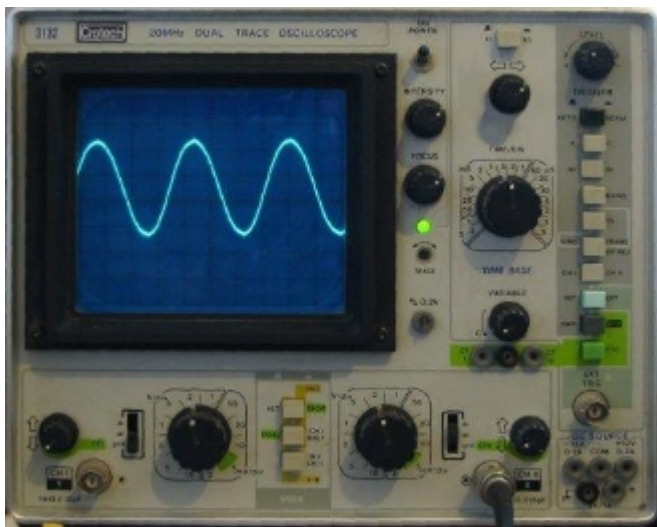

### 3.30 describe an experiment using an oscilloscope to determine the frequency of a sound wave

#### Experiment: To determine the frequency of a sound wave



1. Sound is produced by a loudspeaker.
2. The microphone catches the sound and transmits it into electrical signal.
3. The electrical signal is feed to the oscilloscope.
4. The oscilloscope displays the electrical signal as wave pattern.
5. The time base knob is adjusted for value 5 ms per division.
6. Now count the number of division occupied by one cycle of the wave.

7. Calculate the time for one cycle (T).
8. Now, frequency,  $f=1/T$

### 3.31 relate the pitch of a sound to the frequency of vibration of the source

The sharpness or dullness of a sound is called its pitch.

The more something vibrates the higher frequency. The higher frequency, the higher pitch. So the more vibrations the higher pitch.

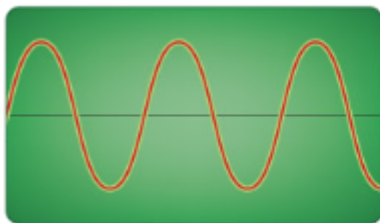

low-pitched sound

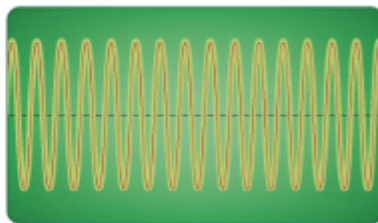

high-pitched sound

### 3.32 relate the loudness of a sound to the amplitude of vibration.

The bigger the vibration the higher the amplitude. The higher the amplitude the louder the sound.

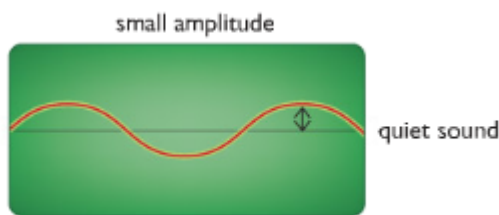
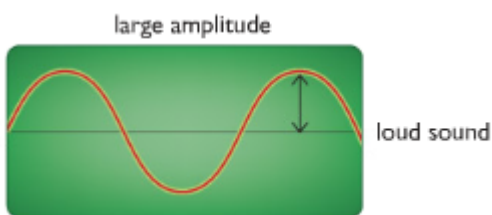

## Section 4: Energy resources and energy transfer

[[toc]]

### (a) Units

**4.1 use the following units: kilogram (kg), joule (J), metre (m), metre/second (m/s), metre/second<sup>2</sup> (m/s<sup>2</sup>), newton (N), second (s), watt (W).**

Unit of mass: kilogram(kg) Unit of energy: joule(J) Unit of distance: metre(m) Unit of speed or velocity: metre/second (m/s) Unit of acceleration: metre/second<sup>2</sup>(m/s<sup>2</sup>) Unit of force: newton (N) Unit of time: second (S) Unit of power: watt(W)

### (b) Energy transfer

**4.2 describe energy transfers involving the following forms of energy: thermal (heat), light, electrical, sound, kinetic, chemical, nuclear and potential (elastic and gravitational)**

Thermal energy: The energy which is released by a hot object when it cools down is called thermal energy. E.g: If we rub our hands together, kinetic energy will transform into thermal energy.

Light energy: The energy which is released from luminous object is called light energy. E.g.: In a filament lamp, electrical energy is converted to heat energy and light energy.

Electrical energy: The energy of charged object is called electrical energy. E.g.: In an electric generator, kinetic energy is converted to heat and electrical energy.

Sound energy: The energy by which we can hear is called sound energy. E.g.: Clapping our hands will convert kinetic energy to sound and little amount of heat energy.

Kinetic energy: The energy of a moving object is called kinetic energy. E.g.: In a ceiling fan, electrical energy is converted to kinetic energy.

Chemical energy: The energy which is released by chemical reaction is called chemical energy. E.g: In a motor car, chemical energy is converted to heat, electrical and kinetic energy.

Nuclear energy: The energy which is released by nuclear reaction is called nuclear energy. E.g.: Energy is nuclear power stations.

Potential energy: The energy which is gained by changing size, shape and position of an object is called potential energy. E.g: Raise a ball 10m above ground, it will gain gravitational potential energy.

#### **4.3 understand that energy is conserved**

Energy is not created or destroyed in any process. It is just converted from one form to another.

Wasted energy: When we try to do things, there is some energy converted to unwanted forms. This form of energy is known as wasted energy.

#### **4.4 know and use the relationship:**

Efficiency is the ratio of useful energy output and the total energy input.

$$\text{efficiency} = \frac{\text{useful energy output}}{\text{total energy input}} \times 100\%$$

#### **4.5 describe a variety of everyday and scientific devices and situations, explaining the fate of the input energy in terms of the above relationship, including their representation by Sankey diagrams**

Whenever we are transferring energy, proportion of input energy is wasted. Like a lamp has input energy of 100J. It uses 10J to give light and the other 90J is wasted as heat.

$$\text{efficiency} = \frac{\text{useful energy output}}{\text{total energy input}} \times 100\%$$

$$\text{efficiency} = \frac{10\text{J}}{100\text{J}} \times 100\%$$

$$\text{efficiency} = 0.1\%$$

In a Sankey diagram it is presented like this:



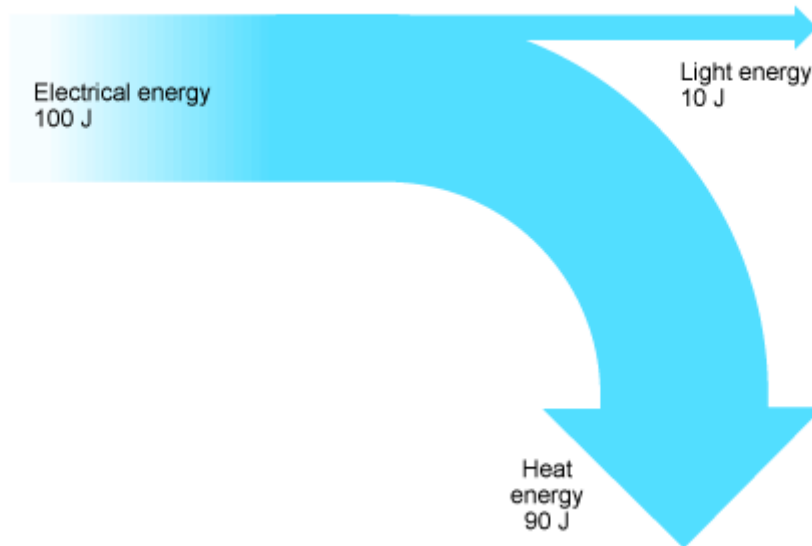

#### 4.6 describe how energy transfer may take place by conduction, convection and radiation

There are three basic ways energy can transfer from place to place: conduction, convection and radiation.

**Conduction:** Thermal conduction is the transfer of heat energy through substance mainly metals, without the substance itself moving. They transfer energy through molecular vibration or free electron diffusion.

Metals are good conductors of heat but non-metals and gases are usually poor conductors of heat. Poor conductors are called insulators. Heat energy is conducted from the hot end of an object to the cold end.

*Heat conduction in metals* The electrons in piece of metal can leave their atoms and move about in the metal as free electrons. The parts of the metal atoms left behind are now charged metal ions. The ions are packed closely together and they vibrate normally continually. The hotter the metal, the more kinetic energy these vibration have. The kinetic energy is transferred from hot parts of the metal to cooler parts by the free electrons. These move through the structure of the metal, colliding with ions as they go.

**Convection:** Convection is the transfer of energy by means of fluids (liquids or gases) by the upward movement of warmer, less dense region of fluid.

The particles in fluids can move from place to place. Convection occurs when particles with a lot of heat energy in a liquid or gas move and take the place of particles with less heat energy in a liquid or gas move and take the place of particles with less heat energy. Heat energy is transferred from hot places to cooler places by convection.

Liquids and gases expand when they are heated. This is because the particles in liquids and gases move faster when they are heated than they do when they are cold. As a result, the particles take up more volume. This is because the gap between particles widens, while the particles themselves stay the same size.

The liquid or gas in hot areas is less dense than the liquid or gas in cold areas, so it rises into the cold areas. The denser cold liquid or gas falls into the warm areas. In this way, convection currents that transfer heat from place to place are set up.

**Radiation:** Radiation is the transfer of energy by means of wave (Infra-red). It doesn't need any medium to flow through. It travels at the speed of light and is actually a specific part of this family of electromagnetic waves. So radiation is the continual emission of infrared waves from the surface of all bodies transmitted without the aid of medium.

#### **4.7 explain the role of convection in everyday phenomena**

##### **1. Household hot-water systems**

The working principle of the household hot-water system which is based on the convection in liquids is as follows:

Water is heated in the boiler by gas burners. The hot water expands and becomes less dense. Hence, it rises and flows into the upper half of the cylinder.

To replace the hot water, cold water from the cistern falls into the lower half of the cylinder and then into the boiler due to the pressure difference.

The overflow pipe is attached to the cylinder just in case the temperature of the water becomes too high and causes a large expansion of the hot water.

The hot-water tap which is led from the overflow pipe must be lower than the cistern so that the pressure difference between the cistern and the tap causes the water to flow out of the tap.

##### **2. Electric kettles.**

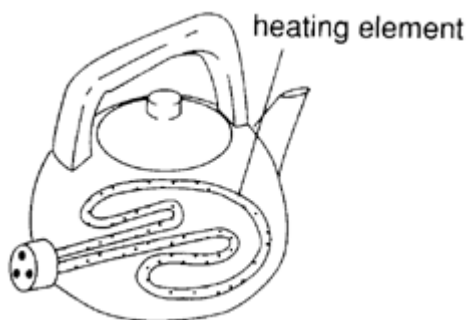

The heating coil of an electric kettle is always placed at the bottom of the kettle.

When the power is switched on, the water near the heating coil gets heated up, expands and becomes less dense. The heated water therefore rises while the cooler regions in the upper part of the body of water descend to replace the heated water.

##### **3. Air-conditioners**

The rotary fan inside an air-conditioner forces cool dry air out into the room. The cool air, being denser, sinks while the warm air below, being less dense, rises and is drawn into the air-conditioner where it is cooled. In this way, the air is recirculated and the temperature of the air falls to the value preset on the thermostat.

##### **4. Refrigerators**

Refrigerators work in very much the same way as air-conditioners. The freezing unit is placed at the top to cool the air so that the cold air, being denser, sinks while the warm air at the bottom rises. This sets up convection currents inside the cabinet which help to cool the contents inside.

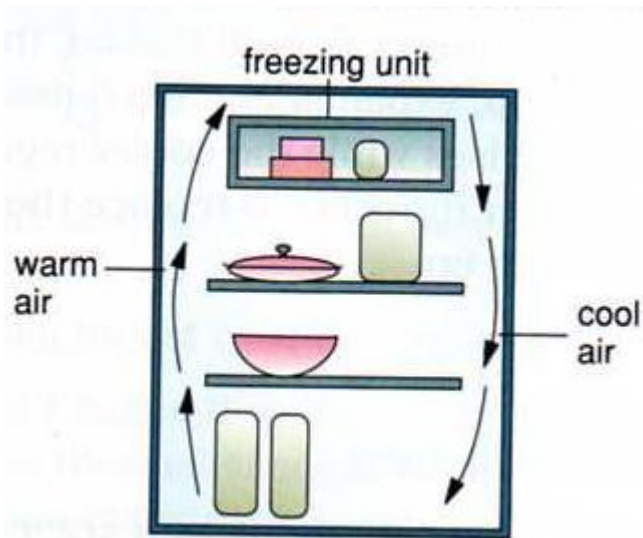

#### 4.8 explain how insulation is used to reduce energy transfers from buildings and the human body.

The bigger the difference in temperature between an object and its surroundings, the greater the rate at which heat energy is transferred. Other factors also effect the rate at which an object transfers energy by heating. These include the:

- **Surface area and volume of the object.** If we compare two objects of the same mass and made of same material, but having different surface areas, the object with the larger surface area will emit infra-red radiation at a higher rate.
- **Material used to make the object.** A conductor conducts heat away more quickly than a insulator. The better its conductivity, the faster it will release heat.
- **Colour and texture of the surface** Dull, black surfaces are better emitter of infrared radiation than shiny, white surfaces.
- **Surface temperature** The rate of transfer of energy by radiation also depends on the surface temperature. The higher the temperature of the surface of the object relative to room temperature, the higher the rate of energy transfer.

**Energy efficient houses and insulation** Reduce heat transfer by conduction:

- Use a vacuum: Conduction needs matter; used in vacuum flasks, some types of double glazing etc.
- Use air: Air is a good insulating material. Many materials like wool, feathers, furs etc. trap air so it cannot circulate. This works because air is a very poor conductor of heat. Houses use fibre glass insulation and cavity walls are sometimes filled with a foam (again, to stop circulation by convection).
- Use water: Wetsuits trap a layer of water around the body because water is a poor conductor.

Reduce heat transfer by convection:

- Use a vacuum: Convection needs gases or liquids, used in vacuum flasks, some types of double glazing, etc.
- Use trapped gas or liquid. This restricts circulation, which is necessary for convection to occur. The size of gap between the sheets of glass is a compromise. A narrow gap makes the effect of convection smaller, but it allows a greater amount of heat transfer by conduction.

Reduce heat transfer by radiation:

- Use shiny surfaces: Very shiny surfaces reflect (heat) radiation well. Fire fighters wear shiny suits to stop heat radiation getting to their bodies. Shiny surfaces are also poor radiators of heat. Space blankets, for example, retain the body heat of athletes or hill-walkers suffering from exposure. This is because they have a shiny inner surface which reflects heat back to the person and also a shiny outer surface which is a poor radiator of infrared.

Other measures:

- Thermostats and computer control systems for central heating can further reduce the heating needs of a house. They stop rooms being heated too much by switching off the heat when a certain temperature is reached.
- Reduction or elimination of draughts from poorly fitting doors and windows.

## **(c) Work and power**

### **4.9 know and use the relationship between work, force and distance moved in the direction of the force:**

Energy is the ability to do work.

work=force x distance

$W = F \times d$

1J of work is done when a force of 1N is applied through a distance of 1m in the direction of the force.

### **4.10 understand that work done is equal to energy transferred**

Doing work means the energy is either decreased or increased. If a weight of 500N is raised 2m, 1000J of work is done. That means energy is increased by 1000J. Therefore work done is equal to energy transferred.

### **4.11 know and use the relationship:**

The energy that the weight has gained is called gravitational potential energy.

gravitational potential energy=mass × gravitational acceleration × height

$G.P.E = mgh$

### **4.12 know and use the relationship:**

*Kinetic energy =  $\frac{1}{2} \times \text{mass} \times \text{velocity}^2$*

$K.E = \frac{1}{2} \times m \times v^2$

### **4.13 understand how conservation of energy produces a link between gravitational potential energy, kinetic energy and work**

An object of mass,  $m$  weights  $mg$  newtons. So the force,  $F$ , needed to lift is  $mg$ . If we raise the object through a distance  $h$ , the work done on the object is  $mgh$ . This is also the gain of GPE.

When the object is raised, it falls-it loses GPE but gains KE. At the end of the fall, all the initial GPE is converted into KE. And that's how energy is conserved.

work done lifting object = gain in GPE = gain in KE of the object just before hitting the ground

#### 4.14 describe power as the rate of transfer of energy or the rate of doing work

Power is the rate of transferring energy or doing work. Its measures how fast energy is transferred. The Watt is the rate of transfer of energy of one joule per second.

#### 4.15 use the relationship between power, work done (energy transferred) and time taken:

power = work done / time

$$P = \frac{W}{t}$$

### (d) Energy resources and electricity generation

#### 4.16 describe the energy transfers involved in generating electricity using:

- **Wind:** Winds are powered by the Sun's heat energy. Wind is a renewable source of energy. Wind mills have been used to grind corn and power machinery like pumps drain lowland areas. Today, wind turbines drive generators to provide electrical energy. Here, kinetic energy is transformed to electrical energy.
- **Water:** Water is used to generate energy in three ways: Hydroelectric power, Tidal power & Wave energy. All the ways uses the same role using the movement of water (K.E.) to rotate that generator and produce electricity. In this case kinetic energy is also transformed to electrical energy.
- **Geothermal resources:** Geothermal energy is heat energy stored deep inside the Earth. The heat in regions of volcanic activity was produced by the decay of radioactive elements. The heated water from the earth's crust is used to rotate turbines in generator. Here, heat energy is converted to kinetic energy which is converted to electrical energy.
- **Solar heating systems:** Solar heating panels absorb thermal radiation and use it to heat water. The panels are placed to receive the maximum amount of the Sun's energy. This produce steam which can be used to drive electricity generators.
- **Solar cells:** Solar energy directly converts light energy into electrical energy.
- **Fossil fuels:** Fossil fuels are natural gas, oil and coal. Those are burned which rotates the turbine in the generator to produce electricity.
- **Nuclear power:** Nuclear fuels like uranium are used in nuclear generator. The heat produced in nuclear reaction is used to produce steam from water which rotates the turbine and produce electricity.

#### 4.17 describe the advantages and disadvantages of methods of large- scale electricity production from various renewable and non- renewable resources.

##### Renewable Resources:

	Advantages	Disadvantages
Wind energy	<ul style="list-style-type: none"> <li>- Relatively cheap to set up</li> <li>- Clean - no waste products</li> </ul>	<ul style="list-style-type: none"> <li>- Only produce energy when it is windy</li> </ul>

	<ul style="list-style-type: none"> <li>- Relatively efficient at converting energy into electricity</li> </ul>	<ul style="list-style-type: none"> <li>- Can be used only in certain places <ul style="list-style-type: none"> <li>- Can be an eyesore</li> <li>- Can produce noise pollution</li> <li>- May kill birds and bats</li> </ul> </li> </ul>
<b>Wave energy</b>	<ul style="list-style-type: none"> <li>- Continuously available</li> <li>- Clean - no waste products</li> <li>- Moderately efficient</li> </ul>	<ul style="list-style-type: none"> <li>- Expensive to set up</li> <li>- Only suitable in certain locations</li> </ul>
<b>Tide energy</b>	<ul style="list-style-type: none"> <li>- Continuously available</li> <li>- Clean - no waste products</li> <li>- Efficient</li> </ul>	<ul style="list-style-type: none"> <li>- Damaging to environment</li> <li>- Expensive to set up</li> <li>- Only suitable in certain geographical locations</li> </ul>
<b>Solar energy</b>	<ul style="list-style-type: none"> <li>- Clean-no waste products</li> </ul>	<ul style="list-style-type: none"> <li>- Expensive in terms of amount of energy produced</li> <li>- Not very efficient method</li> <li>- Energy supply is not continuously available</li> <li>- Best suited to climates with low amounts of cloud cover</li> </ul>
<b>Geothermal energy</b>	<ul style="list-style-type: none"> <li>- Clean- no waste products</li> <li>- Can provide direct heating as well as heat/steam to drive electricity generators</li> <li>- Moderate start-up costs</li> </ul>	<ul style="list-style-type: none"> <li>- Suited only to geographic locations with relatively thin 'crust' or high volcanic activity</li> </ul>
<b>Hydroelectricity</b>	<ul style="list-style-type: none"> <li>- Clean - no waste products</li> <li>- Continuously available</li> </ul>	<ul style="list-style-type: none"> <li>- Needs large reservoirs, which may displace people or wildlife</li> <li>- Can be built only in hilly areas with plenty of rainfall</li> </ul>
<b>Biomass</b>	<ul style="list-style-type: none"> <li>- The carbon dioxide it releases when it burns has only recently been taken out of the atmosphere by crops</li> </ul>	<ul style="list-style-type: none"> <li>- Growing biomass crops instead of food can cause food shortages.</li> </ul>
<b>Wood</b>	<ul style="list-style-type: none"> <li>- With careful management, the supply of wood fuel can be</li> </ul>	<ul style="list-style-type: none"> <li>- Produces pollution and greenhouse gases.</li> </ul>

	maintained indefinitely.	- Wood is more valuable in other sectors rather than producing energy, such as furnitures and buildings.
--	--------------------------	--

**Non-Renewable Resources:**

	<b>Advantages</b>	<b>Disadvantages</b>
<b>Fossil Fuels</b>	<ul style="list-style-type: none"> <li>- Readily available</li> <li>- Easy to produce</li> </ul>	<ul style="list-style-type: none"> <li>- Burning fossil fuels produce greenhouse gases which lead to global warming.</li> <li>- Sulphur causes acid rain.</li> </ul>
<b>Nuclear fuel</b>	<ul style="list-style-type: none"> <li>- Reliable, clean and efficient.</li> <li>- Cost of electricity is low.</li> </ul>	<ul style="list-style-type: none"> <li>- Expensive to build.</li> <li>- Dangerous.</li> </ul>

## Section 5: Solids, liquids and gases

[[toc]]

### (a) Units

**5.1 use the following units: degrees Celsius ( $^{\circ}\text{C}$ ), Kelvin (K), joule (J), kilogram/metre<sup>3</sup> ( $\text{kg}/\text{m}^3$ ), kilogram/metre<sup>3</sup> ( $\text{kg}/\text{m}^3$ ), metre (m), metre<sup>2</sup> ( $\text{m}^2$ ), metre<sup>3</sup> ( $\text{m}^3$ ), metre/second (m/s), metre/second<sup>2</sup> ( $\text{m}/\text{s}^2$ ), newton (N), Pascal (Pa).**

Unit of temperature: degrees Celsius ( $^{\circ}\text{C}$ )

Unit of temperature: Kelvin (K)

Unit of mass:kilogram/metre<sup>3</sup> ( $\text{kg}/\text{m}^3$ )

Unit of density:kilogram/metre<sup>3</sup> ( $\text{kg}/\text{m}^3$ )

Unit of distance:metre (m)

Unit of Area:metre<sup>2</sup> ( $\text{m}^2$ )

Unit of Volume: metre<sup>3</sup> ( $\text{m}^3$ )

Unit of Speed:metre/second (m/s)

Unit of Acceleration: metre/second<sup>2</sup> ( $\text{m}/\text{s}^2$ )

Unit of force: newton (N)

Unit of Pressure: Pascal (Pa)

## (b) Density and pressure

### 5.2 know and use the relationship between density, mass and volume:

Density is the mass per unit volume of an object or fluid.

density = mass/volume

$\rho = m/V$

### 5.3 describe experiments to determine density using direct measurements of mass and volume

#### Experiment: To determine the density of a regularly-shaped object.

**Apparatus:** Vernier calipers, ruler, balance

#### Procedure:

1. Find the mass, using the balance.
2. Determine the volume by taking appropriate measurements and then calculating the volume as follows:

(a) cuboid - measure the length, breadth and height by using a metre rule or a pair of vernier calipers

$$V = l \times b \times h$$

(b) cylinder - measure the diameter and the length.  $V = \pi d^2/4 \times l$

(c) sphere - measure the diameter with a pair of vernier calipers or a pair of engineer calipers together with a metre rule.  $V = 4/3 \pi d^3/8$

**Calculation:** If the mass is in g and the volume is in  $\text{cm}^3$  then, density =  $m/V \text{ g cm}^{-3}$

**Precaution:** The precaution which need to be taken when using the vernier calipers and the metre rule apply here.

#### Experiment: To determine the density of a liquid.

**Apparatus:** Burette, beaker, balance, retort stand.

#### Procedure

1. Find the mass of a clean, dry beaker.
2. Run a volume of the liquid from the burette into the beaker.
3. Find the mass of the beaker and the liquid ( $m_2$ )

**Calculation:** If the masses are measured in g, and the volume in  $\text{cm}^3$ , then the density of the liquid =  $(m_2 - m_1)/V \text{ g cm}^{-3}$

$$= (m_2 - m_1)/V \times 1000 \text{ kg m}^{-3}$$

#### Precaution:

1. When reading the volume of the liquid, make sure that the eye is level with the base of meniscus of the liquid.



2. Keep the beaker on a plain surface.

**Experiment: To determine the density of an irregular shaped object**

1. Determine the mass of the object by using a top pan balance.

Now find, find the volume:

1. Pour some water in a measuring cylinder.
2. Mark the position of the lower meniscus of the water level.
3. Put the object into the water. The water level rises.
4. Mark the position of the lower meniscus again
5. Subtract the two readings and get the volume of the object.

Density:

1. Use the equation  $\rho = \frac{m}{V}$  to find the density.

**5.4 know and use the relationship between pressure, force and area:**

The

pressure = force/area

$p = \frac{F}{A}$

**5.5 understand that the pressure at a point in a gas or liquid which is at rest acts equally in all directions**

Pressure in liquids and gases act equally in all directions, as long as the liquid or gas are not moving.

**Experiment: To prove the above statement.**



4 holes are made at the same depth in a can. So when it is filled with water, the water flowing from these holes moves at same speed. This proves that the pressure is equal in all direction.

**5.6 know and use the relationship for pressure difference:**

pressure difference = height  $\times$  density  $\times$  g

$p = h \times \rho \times g$

**Experiment: To investigate that pressure decreases with height.**



Three holes are made at different height of the can. The water from the hole at the bottom-most of the can travels at highest speed. And the water from top-most hole travels at lowest speed. Thus, proving that pressure increases with depth.

## (c) Change of state

### 5.7 understand the changes that occur when a solid melts to form a liquid, and when a liquid evaporates or boils to form a gas

What is melting:

Changing state from solid to liquid is called melting.

What is melting point?

At a certain pressure the temperature at which a solid start melting is called melting point. The melting point of ice is  $0^{\circ}\text{C}$ .

Describe the process of melting.

When a solid is given heat, the vibration of molecules increases. The repulsion between the molecules increases. Due to greater repulsion than attraction, the molecule take greater equilibrium distance between them. If we increases temperature more, the equilibrium distance increases more. A situation comes when the molecules get separated from each other and move randomly, this state is liquid state.

What is boiling?

Changing state from liquid to gaseous state at a certain temperature is called boiling.

What is evaporation?

Changing state from liquid to gas is called evaporation.

What is boiling point?

The temperature at which a liquid start changing to gas is called boiling point.

Describe the process of boiling.

In liquid state the molecule move randomly around the vessel. If we give further heat, the speed of the molecules increases. If we continue giving heat, a speed reaches when the molecules take off from the liquid state and change into gaseous state. This is how all liquid changes into gas.

### 5.8 describe the arrangement and motion of particles in solids, liquids and gases

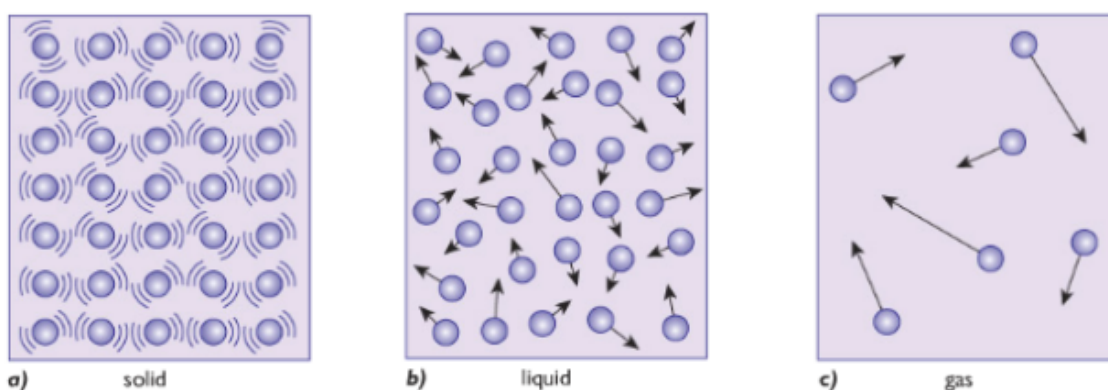

Features	Solid	Liquid	Gas
Arrangement	Regular	Irregular	Random
Movement	Cannot move, vibrate only	Particles can move throughout the liquid slight past each other	Particles can move freely
Energy of Particles	Particles have least kinetic energy	Particles have more kinetic energy than solid	The particles have the most kinetic energy
Attraction between particles	Strong	Strong	Very Weak
Distance between particles (Density)	Tightly packed	Tend to stay close together	Far apart
Shape	3D structure	Takes the shape of the container	No fixed shape
Compression	Cannot be compressed easily.	Cannot be compressed easily.	Can be easily compressed.

## (d) Ideal gas molecules

### 5.9 understand the significance of Brownian motion, as supporting evidence for particle theory

One piece of evidence for the continual motion of particles in a liquid or a gas is called Brownian motion. Particles of a liquid or gas are moving around continually and bump into each other and into tiny particles such as pollen grains. Sometimes there will be more collisions on one side of a pollen grain than on another, and this will make the pollen grain change its direction or speed of movement.

In short:

1. Gases are made up of molecules: We can treat molecules as point masses that are perfect spheres. Molecules in a gas are very far apart, so that the space between each individual

molecule is many orders of magnitude greater than the diameter of the molecule.

2. Molecules are in constant random motion: There is no general pattern governing either the magnitude or direction of the velocity of the molecules in a gas. At any given time, molecules are moving in many different directions at many different speeds.
3. The movement of molecules is governed by Newton's Laws: In accordance with Newton's First Law, each molecule moves in a straight line at a steady velocity, not interacting with any of the other molecules except in a collision. In a collision, molecules exert equal and opposite forces on one another.
4. Molecular collisions are perfectly elastic: Molecules do not lose any kinetic energy when they collide with one another.

### **5.10 understand that molecules in a gas have a random motion and that they exert a force and hence a pressure on the walls of the container**

Pressure comes into play whenever force is exerted on a certain area, but it plays a particularly important role with regard to gases. The kinetic theory tells us that gas molecules obey Newton's Laws: they travel with a constant velocity until they collide, exerting a force on the object with which they collide. If we imagine gas molecules in a closed container, the molecules will collide with the walls of the container with some frequency, each time exerting a small force on the walls of the container. The more frequently these molecules collide with the walls of the container, the greater the net force and hence the greater the pressure they exert on the walls of the container.

Balloons provide an example of how pressure works. By forcing more and more air into an enclosed space, a great deal of pressure builds up inside the balloon. In the meantime, the rubber walls of the balloon stretch out more and more, becoming increasingly weak. The balloon will pop when the force of pressure exerted on the rubber walls is greater than the walls can withstand.

### **5.11 understand why there is an absolute zero of temperature which is $-273^{\circ}\text{C}$**

Temperature affects the pressure of particles of gases. The higher the temperature, the higher the energy in particles and more the pressure. If we decrease the temperature the result will be the exact opposite. As we cool the gas, the pressure keeps decreasing. The pressure of the gas cannot become less than zero. The temperature at which the pressure of the gas is decreased to 0, that temperature is called absolute zero. It is approximately  $-273^{\circ}\text{C}$ .

### **5.12 describe the Kelvin scale of temperature and be able to convert between the Kelvin and Celsius scales**

Temperature in K = temperature in  $^{\circ}\text{C}$  + 273

Temperature in  $^{\circ}\text{C}$  = temperature in K - 273

### **5.13 understand that an increase in temperature results in an increase in the average speed of gas molecules**

The kinetic theory explains why temperature should be a measure of the average kinetic energy of molecules. According to the kinetic theory, any given molecule has a certain mass; a certain velocity; and a kinetic energy of  $\frac{1}{2}mv^2$ . As we said, molecules in any system move at a wide variety of different velocities, but the average of these velocities reflects the total amount of energy in that system. If we increase the temperature, the kinetic energy will increase. This will result in an increase of average velocity of the gas molecules.

**5.14 understand that the Kelvin temperature of the gas is proportional to the average kinetic energy of its molecules**

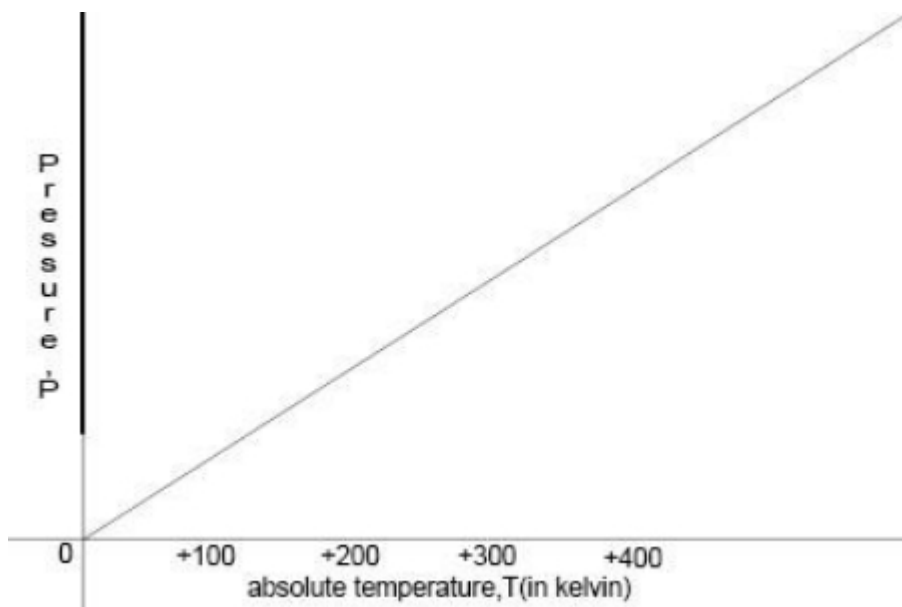

Temperature in Kelvin is directly proportional to the average kinetic energy of molecules. If we increase the temperature, kinetic energy as well as pressure will increase as well.

**5.15 describe the qualitative relationship between pressure and Kelvin temperature for a gas in a sealed container**

The number of gas particles and the space, or volume, they occupy remain constant. When we heat the gas the particles continue to move randomly, but with a higher average speed. This means that their collisions with the walls of the container are harder and happen more often. This results in the average pressure exerted by the particles increasing.

When we cool a gas the kinetic energy of its particles decreases. The lower the temperature of a gas the less kinetic energy its particles have - they move more slowly. At absolute zero the particles have no thermal or movement energy, so they cannot exert pressure.

**5.16 use the relationship between the pressure and Kelvin temperature of a fixed mass of gas at constant volume:**

$$p_1 T_1 = p_2 T_2$$

**5.17 use the relationship between the pressure and volume of a fixed mass of gas at constant temperature:**

$$p_1 V_1 = p_2 V_2$$

Provided the temperature is constant, the average speed of the particles stays the same. If the same number of particles is squeezed into a smaller volume, they will hit the container walls more often. Each particle exerts a tiny force on the wall with which it collides. More collisions per second means a greater average force on the wall and, therefore, a greater pressure.

# Section 6: Magnetism and electromagnetism

[[toc]]

## (a) Units

### 6.1 use the following units: ampere (A), volt (V), watt (W).

Unit of current: ampere (A)

Unit of potential difference: volt (V)

Unit of power: watt (W)

## (b) Magnetism

### 6.2 understand that magnets repel and attract other magnets and attract magnetic substances

Magnets are able to attract objects made from magnetic materials such as iron, steel, etc. Other objects like plastic, rubber are non-magnetic substance. They can't attract magnet.

Magnets have two poles: North Pole and South Pole. North Pole and South Pole attract each other. Similar poles like North Pole and North Pole or South Pole and South Pole repel each other.

### 6.3 describe the properties of magnetically hard and soft materials

<b>Magnetically hard materials</b>	<b>Magnetically soft materials</b>
Needs time to become magnetized	Easily gets magnetized
Once magnetized, the magnetism remains permanently	Loses its magnetism easily
Magnets with magnetically hard materials are known as permanent magnets	Magnets with magnetically soft materials are known as temporary magnets
Eg: Steel	Eg: Iron

### 6.4 understand the term 'magnetic field line'

Magnetic field is a volume of space where magnetism can be detected.

Magnetic fields are drawn using lines of force or flux lines. These lines are imaginary but they:

- show the shape of magnetic field.
- show the direction of the magnetic field – the field lines travel from north to south.
- show the strength of the magnetic field – the field lines are closest together where the magnetic field is strongest.

### 6.5 understand that magnetism is induced in some materials when they are placed in a magnetic field

If you keep a material in a magnetic field, eventually after a period of time, that material will be magnetized.

Example:

- Place a magnetically soft material close to a strong magnet. The soft iron bar becomes an induced magnet with the end nearer the magnet having opposite polarity to that of the magnet.
- A steel bar is placed inside a coil. After a while the bar becomes magnetized due to the magnetic induction from solenoid. The polarities of the magnet depend on the direction of current flow.

### **6.6 describe experiments to investigate the magnetic field pattern for a permanent bar magnet and that between two bar magnets**

**Experiment: To investigate the magnetic field pattern for a permanent bar magnet.**

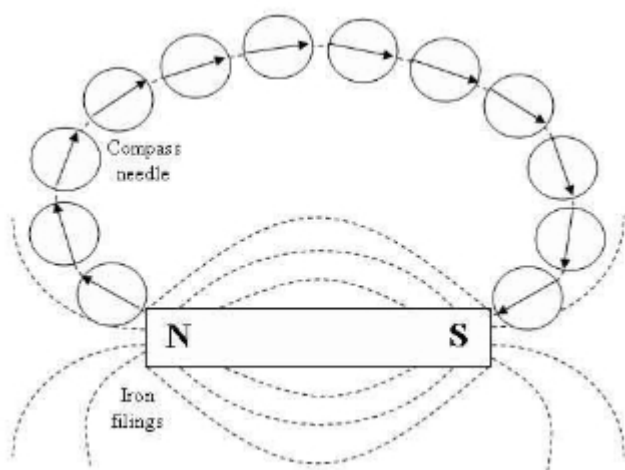

**Apparatus:** Bar magnet, plotting compass and a plain paper.

**Procedure:**

1. Place the bar magnet at the centre of the piece of paper so that its N-pole faces North and its S-pole faces South.
2. Starting near one pole of the magnet, the position ends, N and S, of the compass needle are marked by pencil dots X and Y. The compass is then moved until one end is exactly over Y and the new position of other end is marked with a third dot.
3. Repeat the process of marking the dots. Join the series of dots and this will give the plot of the field lines of the magnetic field.

**Precautions:**

1. Check that the plotting compass in good working order.

2. Ensure that there is no strong magnetic field around the plotting compass.

### Experiment: To plot magnetic field using iron fillings

**Apparatus:** Iron fillings, Bar magnet

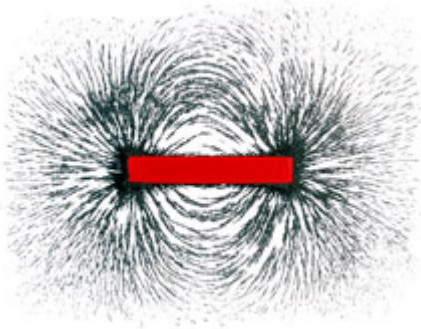

#### Procedure:

Place a sheet of paper over a bar magnet. Sprinkle a thin layer of Iron filings over the paper and then tap the paper gently. The iron filings act like thousands of tiny compasses and point themselves along the lines of flux.

#### 6.7 describe how to use two permanent magnets to produce a uniform magnetic field pattern.

**Apparatus:** Two bar magnets

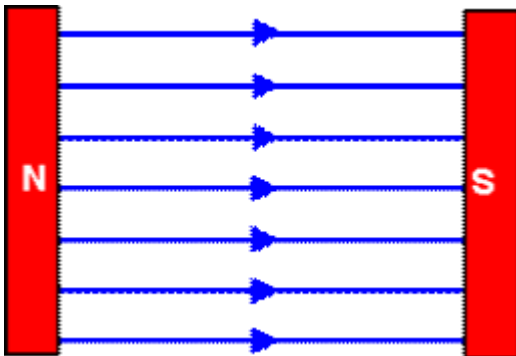

#### Procedure:

By keeping the opposite poles face each other. The region between the poles would establish magnetic field that would be uniform.

## (c) Electromagnetism

#### 6.8 understand that an electric current in a conductor produces a magnetic field round it

When a current flows through a wire a magnetic field is created around the wire. This phenomenon is called electromagnetism. The field around the wire is quite weak and circular in shape. The direction of



the magnetic field depends up the direction of the current and can be found using the right-hand grip rule.

### 6.9 describe the construction of electromagnets

If a temporary magnet is wrapped with a wire into a coil and pass current to it, the magnet will become magnetized. This way electromagnets can be constructed.

### 6.10 sketch and recognize magnetic field patterns for a straight wire, a flat circular coil and a solenoid when each is carrying a current

A field around a straight wire is simply a series of circles around the wire.

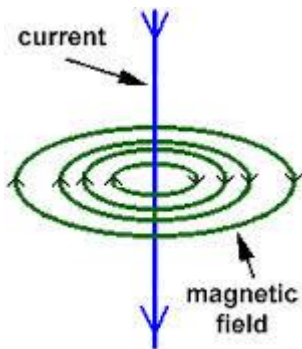

A field around a solenoid is similar to that of a bar magnet.

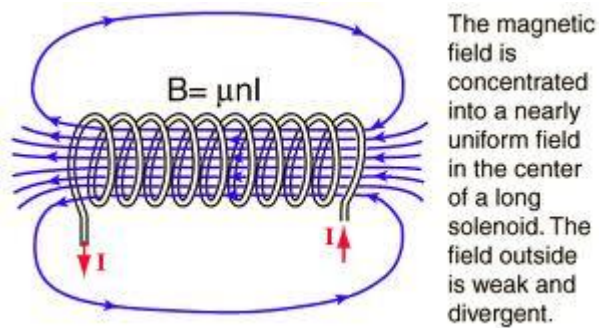

A field around a flat coil is basically like a single wire, but there are two.

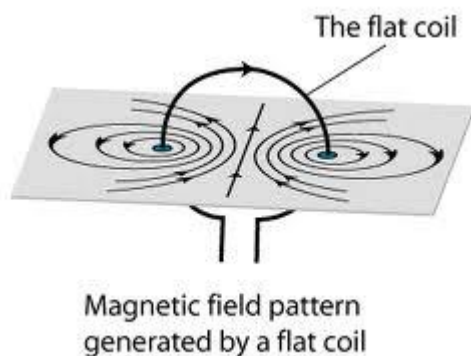

**6.11 understand that there is a force on a charged particle when it moves in a magnetic field as long as its motion is not parallel to the field**

A charged particle has a magnetic field around it. When a charged particle moves through another magnetic field, it experiences a force. This is because of the overlapping of the two magnetic fields. However, if the charged particle is moved parallel to that field, no force will be exerted. As an electric current is a flow of electrons, we can see this effect when a wire carrying the current is put into a magnetic field too.

**6.12 understand that a force is exerted on a current-carrying wire in a magnetic field, and how this effect is applied in simple d.c. electric motors and loudspeakers**

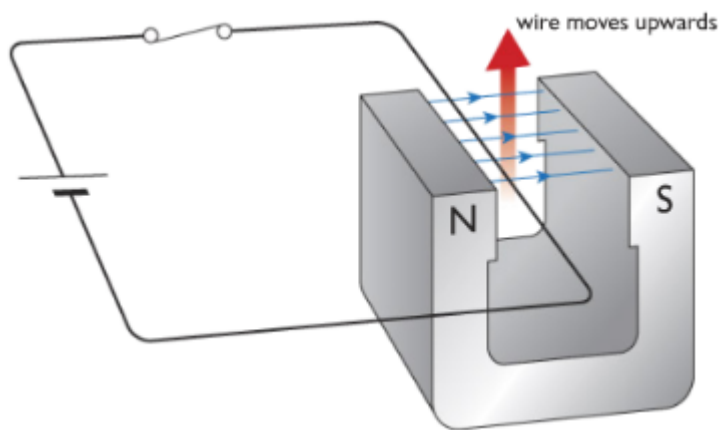

If we pass a current through a piece of wire held at right angle to the magnetic field of a magnetic field of a magnet, the wire will move. The motion is the result of forces created by overlapping magnetic field around the wire and the magnet.

When a current flows along a wire a cylindrical magnetic field is created around the wire. If the wire is placed between the poles of a magnet, the two fields overlap. In certain places, the fields are in the same direction and so reinforce each other, producing a strong magnetic field. In other places, the fields are in opposite directions, producing a weaker field. The wire experiences a force, pushing it from the stronger part of the field to the weaker part. This is called the motor effect.

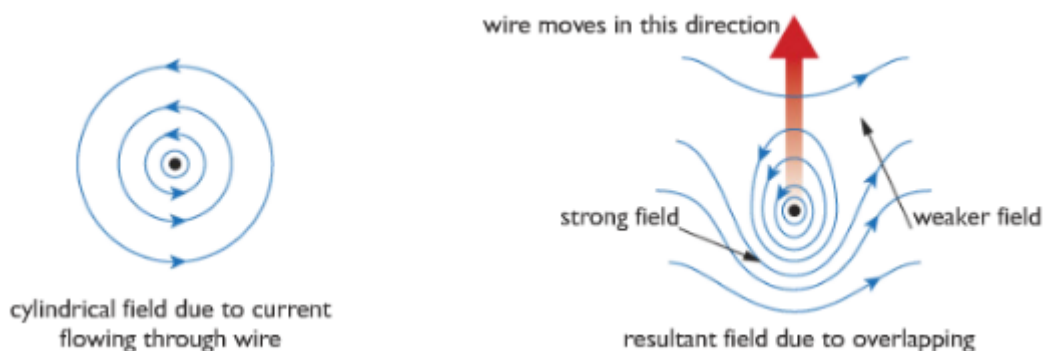

The moving - coil loudspeaker:

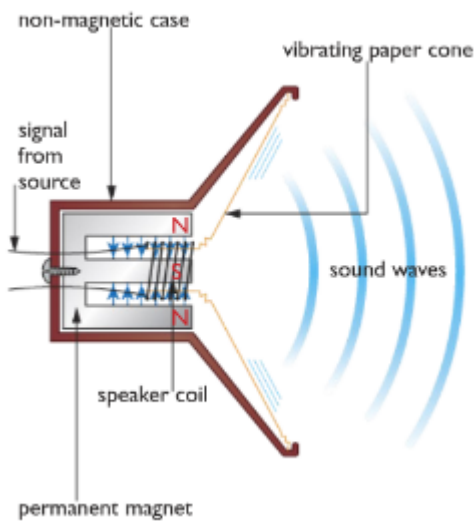

Signals from a source, such as an amplifier, are fed into the coil of the speaker as currents that are continually changing in size and direction. The overlapping fields of the coil and the magnet therefore create rapidly varying forces on the wires of the coil, which cause the speaker cone to vibrate. These vibrations create the sound waves we hear.

The electric motor:

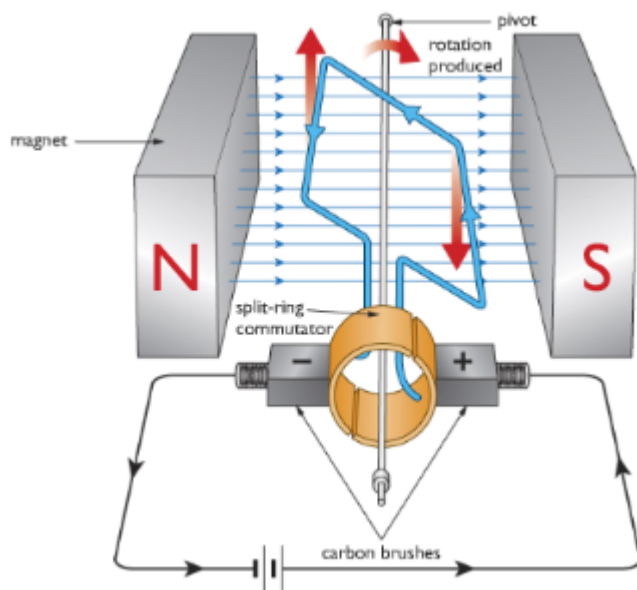

As current passes around the loop of wire, one side of it will experience a force pushing it upwards. The other side will feel a force pushing it downwards, so the loop will rotate. Because of the split ring, when the loop is vertical, the connections to the supply through brushes swap over, so that the current flowing through each side of the loop changes direction. The wire at the bottom is now pushed upwards and the wire at the top is pushed downwards – so the loop carries on turning. The arrangement of brushes and split ring changes the direction of the current flowing through the loop every half turn, which means the rotation can be continuous.

**6.13 use the left hand rule to predict the direction of the resulting force when a wire carries a current perpendicular to a magnetic field**

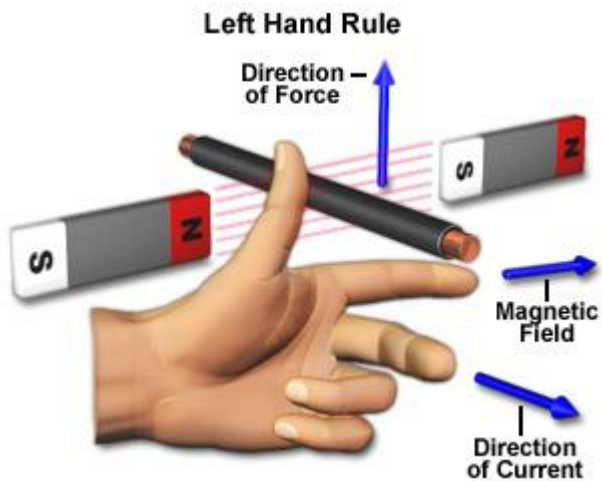

The left hand rule shows the direction of force, magnetic field and current when a wire carries a current perpendicularly to a magnetic field.

The pointing finger points the magnetic field from North to South

The middle finger points the direction of current in wire.

The thumb shows the resulting force.

**6.14 describe how the force on a current-carrying conductor in a magnetic field increases with the strength of the field and with the current.**

Ways to increase the force produced in motors:

- Increase the number of turns or loops of wire (to make a coil)
- Increase the strength of magnetic field
- Increase the current flowing through the loop of wire

## **(d) Electromagnetic induction**

**6.15 understand that a voltage is induced in a conductor or a coil when it moves through a magnetic field or when a magnetic field changes through it and describe the factors which affect the size of the induced voltage**

When a wire cuts the magnetic field of a magnet, a voltage is induced in the wire. This phenomenon is called electromagnetic induction.

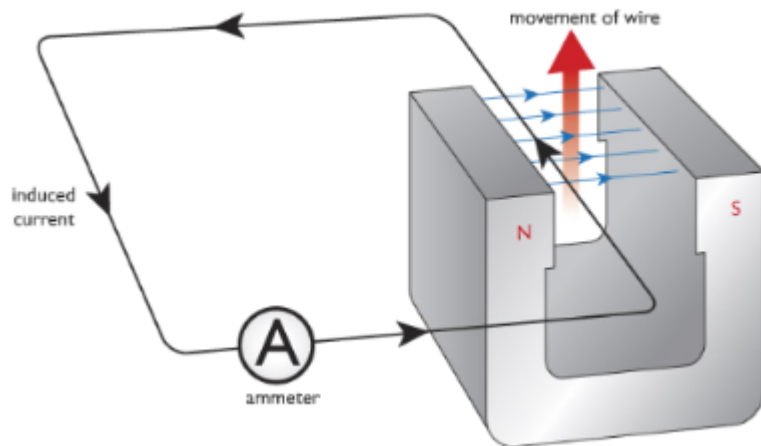

If we move a wire across a magnetic field at right angles, a voltage is induced in the wire. The size of the induced voltage can be increased by:

1. moving the wire more quickly
2. using a stronger magnet
3. wrapping the wire into a coil so that more pieces of wire move through the magnetic field.

We can generate a voltage and current by pushing a magnet into a coil. The size of induced voltage can be increased by:

1. moving the magnet more quickly
2. using a stronger magnet
3. using a coil with a larger cross-sectional area.

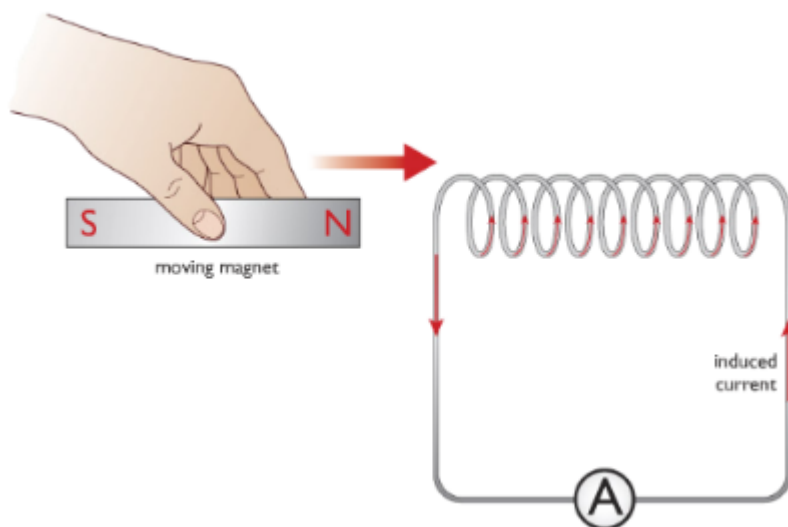

Faraday's Law of Electromagnetic Induction:

"The size of the induced voltage across the ends of a wire (coil) is directly proportional to the rate at which the magnetic lines of flux are being cut."

This says that:

- a voltage and current are generated when a conductor such as wire cuts through the magnetic field lines.
- the faster the lines are cut the larger the induced voltage and current.

**6.16 describe the generation of electricity by the rotation of a magnet within a coil of wire and of a coil of wire within a magnetic field and describe the factors which affect the size of the induced voltage**

In a generator, when the coil rotates, its wire cut through magnetic field lines and a current is induced in them. If we watch just one side of the coil, we see that the wire moves up through the field and then down for each turn of the coil. As a result, the current induced in the coil flows first in one direction and then in the opposite direction. This kind of current is called alternating current. A generator that produces alternating current is called an alternator. The size of the induced voltage can be increased by using much stronger magnets, many more turns of wire on the coil and spinning the coil much faster.

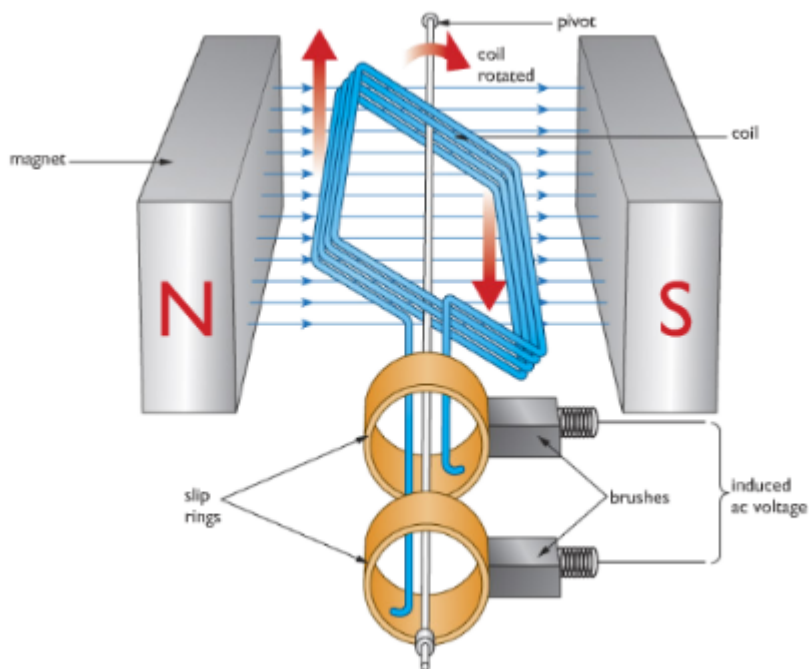

**6.17 describe the structure of a transformer, and understand that a transformer changes the size of an alternating voltage by having different numbers of turns on the input and output sides**

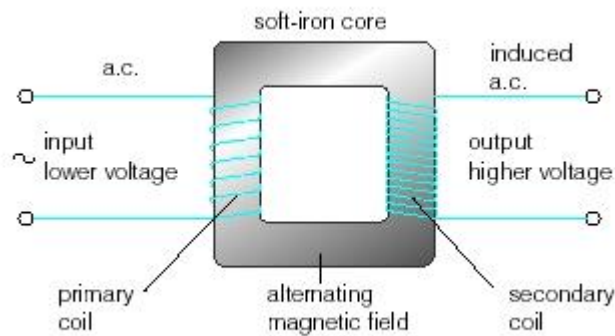

A transformer is a device that helps to reduce or increase voltage in a wire or electric line. This is made of two soft iron core linking to the coils at the two end of the transformer. The first coil is called the primary coil and the second one is called the secondary coil. When alternating current is passed through a coil, the magnetic field around it is continuously changing. The changing magnetic field will cut the secondary coil and induce voltage in it, and that's how current is passed. If the secondary coil has more turns than the primary coil, it is a step-up transformer where output the voltage will increase. If the secondary coil has less turns than the primary, it is a step-down transformer where the output voltage will decrease.

Why transformer doesn't work with direct current?

Transformers only work if the magnetic field around the primary coil is changing. Transformers will therefore only work with ac currents and voltages. They will not work with dc current and voltages.

**6.18 explain the use of step-up and step-down transformers in the large- scale generation and transmission of electrical energy**

After generating electricity, electric currents are passed to a step-up transformer which increase the voltage and decrease the current. This is because higher currents need wide and expensive wire to pass through. Or else, energy is lost in form of heat. Using transformers mean we can have a solution to this problem. Before the electricity reaches home, those are passed through step-down transformers to decrease the voltage and increase the current at the same time.

**6.19 know and use the relationship between input (primary) and output (secondary) voltages and the turns ratio for a transformer:**

input voltage/output voltage=number of turns on primary coil/number of turns on secondary coil

$$V_p/V_s = n_p/n_s$$

**6.20 know and use the relationship: for 100% efficiency**

If a transformer is 100% efficient, the electrical energy entering the primary coil is equal to the electrical energy leaving the secondary coil.

Input power = output power

$$V_p I_p = V_s I_s$$

# Section 7: Radioactivity and particles

[[toc]]

## (a) Units

**7.1 use the following units: Becquerel (Bq), centimetre (cm), hour (h), minute (min), second (s).**

Unit of radioactivity: Becquerel (Bq)

Unit of length: centimetre (cm)

Unit of time: hour (h)

Unit of time: minute (min)

Unit of time: second (s)

## (b) Radioactivity

**7.2 describe the structure of an atom in terms of protons, neutrons and electrons and use symbols such as  $^{14}_6\text{C}$  to describe particular nuclei**

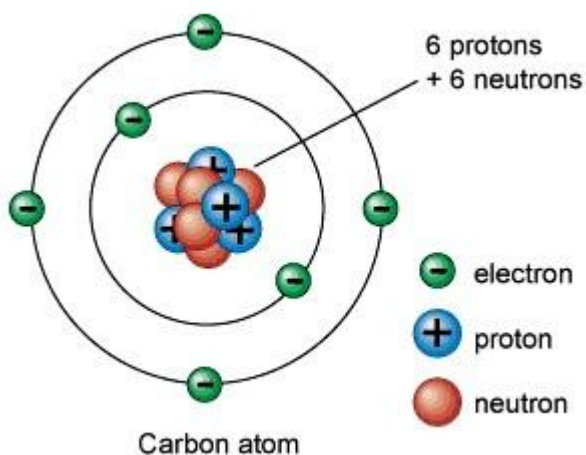

An atom is a tiny particle with nucleus in the centre and electrons orbiting it. A nucleus is made up of proton and neutron.

An atom is presented in this way =  $^X_Z\text{Z}$

Z=Symbol of the atom

X=Mass Number

Y=Atomic Number

**7.3 understand the terms atomic (proton) number, mass (nucleon) number and isotope**



Atomic Number: Atomic number is the number of protons in an atom

Mass number: Mass number is the addition number of protons and neutrons

Isotope: Isotope is an element which has the same atomic number as the original atom but different mass number.

#### **7.4 understand that alpha and beta particles and gamma rays are ionising radiations emitted from unstable nuclei in a random process**

Stability of isotopes: The protons are held in a nucleus by nuclear force. Nuclear force is strong short ranged force. On the other hand, the protons try to repel away from each other due the electric force formed by the similar charges of protons. So the presence of neutrons help nucleus to stabilize. Too many or too few of neutrons can cause instability and may eventually decay, thus giving out ionising radiation along with energy.

Ionising radiation: When unstable nuclei decay they gives out ionising radiation. Ionising radiation causes atom to gain or lose electrons to form ions. Basically there are three types of ionizing radiation: alpha, beta and gamma.

Alpha radiation: Alpha radiation consists of fast-moving helium nucleus.

Beta radiation: Beta radiation consists of fast-moving electron.

Gamma rays: Gamma ray is an electromagnetic wave.

#### **7.5 describe the nature of alpha and beta particles and gamma rays and recall that they may be distinguished in terms of penetrating power**

Nature of radiation

Alpha radiation has been identified as a stream of helium nuclei. In other words, an alpha particle is actually a positively-charged helium nucleus comprising two protons and two neutrons. It is a very stable particle.

Beta radiation has been identified as a stream of high-energy electrons. In other words, a beta particle is actually a negatively-charged electron. It is formed by a nucleus decay process.

Gamma radiation has been identified as high-frequency electromagnetic radiation. In other words, they are electromagnetic waves of very short wavelength.

Ionising power

When a fast-moving particle such as an alpha or beta particle collides with an atom, an electron may be ejected from the atom, resulting in a charged ion. Alpha particles have the greatest ionising power compared to beta and gamma radiation because it is heavier and large and is more likely to collide with atoms, resulting the greatest number of ions in their tracks. Compared with gamma rays, beta particles are more ionizing.

Penetrating power

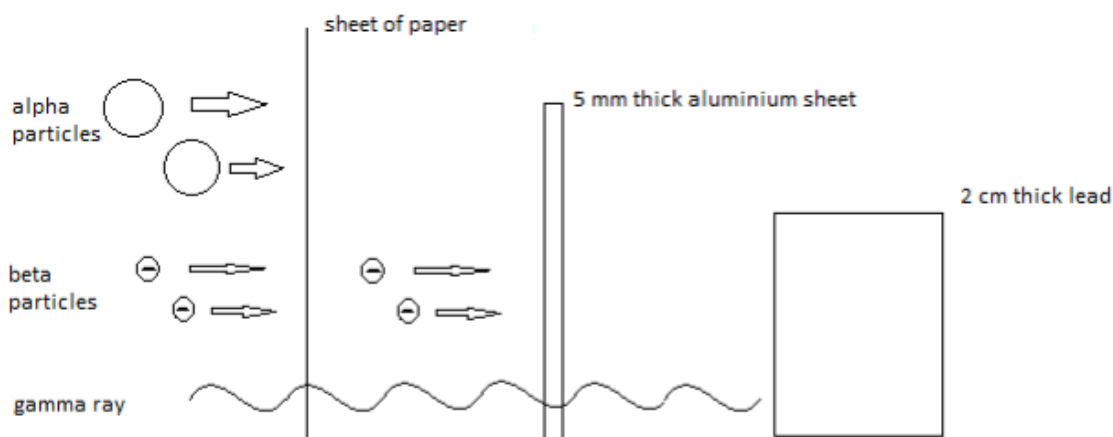

The Figure shows the relative penetrating power of three kinds of radiation. The alpha particles can be stopped by a sheet of paper whereas beta particles and gamma rays penetrate it easily. This shows that alpha particles have the least penetrating power. Infact, it has a range of only few centimeters in air. Beta particles have a range of several metres in air but can be stopped by a 5mm tick aluminium sheet. Gamma rays are the most penetrating, having a range of a few hundred metres in air and can only be stopped by a 2 cm-thick lead shield.

Radiation	Ionising power	Penetrating range in air	Example of range in air	Radiation stopped by
Alpha, $\alpha$	strong	weak	5-8cm	paper
Beta, $\beta$	medium	medium	500-1000 cm	Thin aluminium
Gamma, $\gamma$	weak	strong	Virtually infinite	Thick lead sheet

### 7.6 describe the effects on the atomic and mass numbers of a nucleus of the emission of each of the three main types of radiation

Alpha ( $\alpha$ ) decay:

In alpha decay, alpha particles takes away 4 nucleons with itself which reduce the mass number of the element by 4. Alpha particles have 2 protons with it, which reduce the atomic number of the element by 2.

Example:

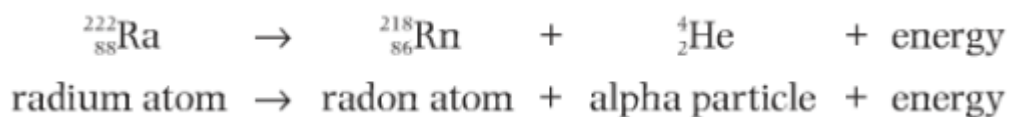

Beta ( $\beta$ )decay:

Beta particle is formed when a neutron splits to form a proton and an electron. Beta particle practically has no mass, so it doesn't affect the mass number of the element. As beta particles have a charge of

-1, the elements atomic number is increased by +1.

Example:



Gamma ( $\gamma$ ) decay:

After an unstable nucleus has emitted an alpha or beta particle it sometimes has surplus energy. It emits this energy as gamma radiation. Gamma ray is an electromagnetic wave and doesn't affect the mass number or atomic number of the element.

### 7.7 understand how to complete balanced nuclear equations

In a nuclear equation, in the left hand side the total mass number should be equal to the mass number in the right hand side. And the atomic number should be equal in both sides.

Here, Uranium experienced an alpha decay:

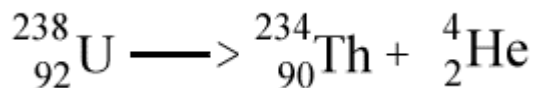

Here, Lithium faced beta decay:

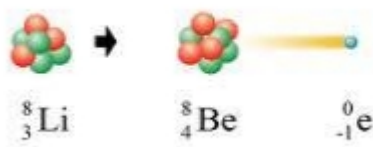

### 7.8 understand that ionising radiations can be detected using a photographic film or a Geiger-Muller detector

Photographic film: Photographic film is a traditional way to detect presence of ionising radiation nearby. Ionising radiations imprints photographic plates. That is the film becomes foggy when it is exposed to a certain amount of radiation.

Geiger Muller: Geiger Muller tube is used to measure the level of radiation. It is a glass tube with an electrically conducting coating on the inside surface. The tube has a thin window made of mica. The tube contains low pressured gases. In the middle of the tube, there is an electrode which is connected to a high voltage supply via a resistor. When ionising radiation enters the tube through the glass, it causes the low pressured gas to form ions. As ions are charged particle they allow to flow a pulse of current in the electrode which is detected by an electronic circuit.

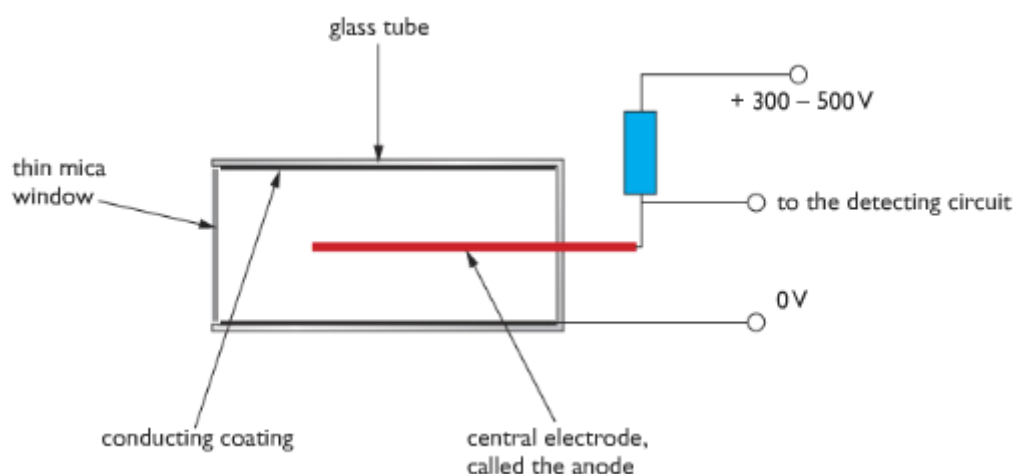

Counting circuit is fitted with a GM tube so that it can measure how many ionising particles entered GM tube. Rate meters are fitted with GM tube to measure the number of ionising events per second, and so give a measure of the radioactivity in Becquerels. Rate meters have a loudspeaker output so the level of radioactivity is indicated by the rate of clicks produced.

### 7.9 explain the sources of background radiation

Background radiation is low-level ionizing radiation that is produced all the time. The background radiation has many sources including natural and artificial ones.

Natural sources:

**Cosmic rays:** Violent nuclear reactions in stars and exploding stars called supernovae produce very energetic particles and cosmic rays that continuously bombard the Earth. Lower energy cosmic rays are given out by the Sun. Our atmosphere gives us fairly good protection from cosmic rays.

**Rocks and soil:** Some of the radiation comes from rocks in the Earth's crust. When the Earth was formed, around 4.5 billion years ago, it contained many radioactive isotopes. Some decayed very quickly but others are still producing radiation. Some of the decay products of these long-lived radioactive materials are also radioactive, so there are radioactive isotopes with much shorter half-lives still present in the Earth's crust.

**Living things:** Plants absorb radioactive materials from the soil and these pass up the food chain. Also we breathe small amount of radioactive isotopes of carbon, carbon - 14. We continuously renew the amount of radioactive isotopes in our bodies.

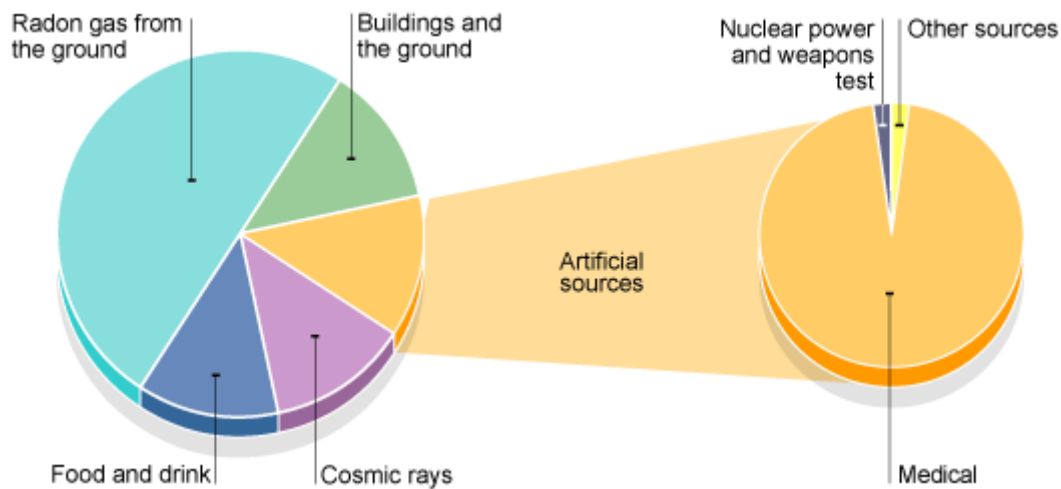

Artificial sources:

Human activity has added to background radiation by creating and using artificial sources of radiation. These include radioactive waste from nuclear power stations, radioactive fallout from nuclear weapons testing and medical x-rays.

Artificial sources account for about 15 percent of the average background radiation dose. Nearly all artificial background radiation comes from medical procedures such as receiving x-rays for x-ray photographs.

**7.10 understand that the activity of a radioactive source decreases over a period of time and is measured in Becquerels**

Radioactive substance keeps decaying in a random process. As it decays, its activity is reduced over a period of time. The unit of Radioactivity is Becquerels.

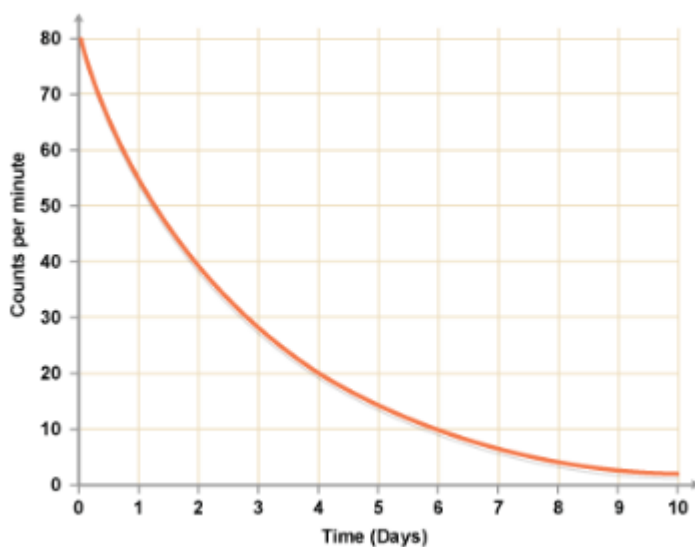

If we plot a graph of activity of a radioactive isotope against time we will get something like the one above. The graph falls steeply at first and more slowly after time. This is because the activity gets smaller, and the smaller the activity the slower the activity will decrease. This kind of decrease proportional of activity to time is called exponential decay.

### 7.11 understand the term 'half-life' and understand that it is different for different radioactive isotopes

"Half-Life" is the amount of time taken for the activity of any radioactive substance to reduce to half. Each radioactive isotope decays in different speeds. So half life is different for different types of isotopes.

### 7.12 use the concept of half-life to carry out simple calculations on activity

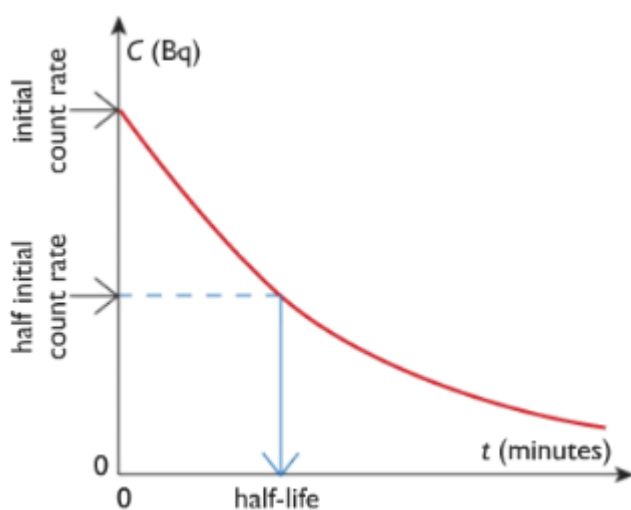

To find half life, plot graph of the activity against time. Point out the half of the activity and draw line to match the time as done in the figure. The time is your half-life.

Half life calculation:

Example: The half life of an isotope is 3 hours. If the initial activity of the isotope is 544 Bq, what will be the count rate after 15 hours?

Ans: 15 hours = 3 x 5 hours Therefore, the activity will be halved 5 times.  
 $544 \times \frac{1}{2} \times \frac{1}{2} \times \frac{1}{2} \times \frac{1}{2} \times \frac{1}{2} = 17$  The activity will be 17 Bq after 15 hours.

### Experiment: How to find the Half-life of a radioactive isotope.

**Apparatus:** Geiger-Muller tube

**Procedure:** To measure the half-life of a radioactive material we must measure the activity of the sample at regular times. This is done using a Geiger - Muller tube linked to a rate meter. Before taking measurements from the sample, we must measure the local background radiation. We must subtract the background radiation from measurements taken from the sample so we know the radiation produced by the sample itself. We then measure the rate of decay of the sample at regular time intervals. The rate of decay is shown by the count rate on the rate meter. The results should be recorded in a table.

The rate of decay corrected from background radiation is proportional to the amount of radioactive isotope present. If we plot a graph of rate of decay against time, we can measure the half-life from the graph.

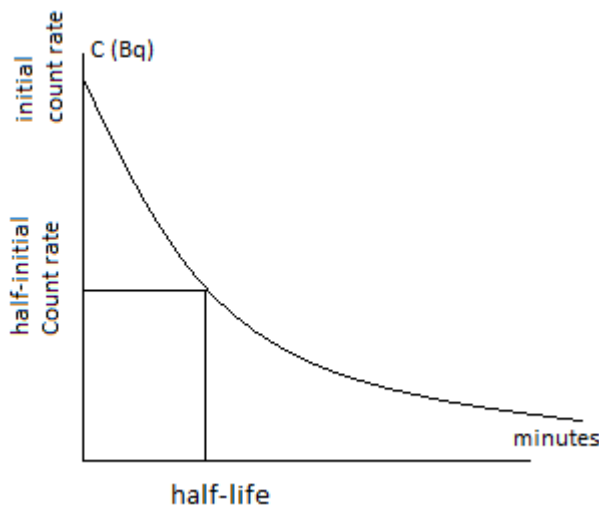

### 7.13 describe the uses of radioactivity in medical and non-medical tracers, in radiotherapy, and in the radioactive dating of archaeological specimens and rocks

Radioactive materials are being used in many different ways in medicine, industry and agriculture. There are five main uses of radioactive materials. They are used in tracers, as penetrating radiation, as power sources, for medical treatment and for dating archaeological specimens.

1. *Tracers* The ability of detectors to measure small concentrations of a radioactive material is made use of in tracer applications. Tracers are used extensively in medicine. Iodine, for example accumulates readily in the thyroid gland. By using radioactive iodine - 131 and finding out the rate at which it accumulates in the thyroid, the thyroid functions may be monitored.

In industry, a typical use of tracers is in the study of the wear and tear of the moving parts of machinery. This can be done by tagging a radioisotope onto the surfaces of the moving parts under investigation and then finding the amount rubbed off. Another major use in industry is in the detection of leaks in underground pipe.

By introducing a suitable radioactive tracer into the pipe, the leak unusually high count rate at the area of the leak. This will save both time and money in locating and repairing the leak.

In agriculture, radioactive phosphorus-32 is used as a tracer to find out how well the plants are absorbing phosphates which are crucial to their growth. The complicated mechanism of photosynthesis has also been studied using tracers.

2. *Penetrating radiation* Cobal-60 emits penetrating gamma rays which can be used to penetrate deep into welding to reveal faults. Normal X-rays are not able to perform this task. Gamma rays are also used to photograph the inside of an engine to reveal any cracks.

In the area of manufacturing, suitable radioactive sources are used to check the thickness of rolled sheets of metal, paper or plastic. In other words, the gamma radiation source acts as a thickness gauge.

A beta source cannot be used in this case because it is not penetrative enough when compared to the gamma source. However, a beta source can be used to check the thickness of rolled sheets of paper or plastic.

In the food industry, the high penetration power of gamma rays is used to kill any bacteria in pre-packaged or frozen foods. This will sterilize the food and prevent food poisoning.

3. *Power sources* Uranium-235 is the most common fuel in nuclear power stations. Other radioactive materials can be used as portable sources. For example, some satellites use radioactive materials as their source of power, which comes from the energy released when these radioactive materials decay.

Some fire alarms contain a small amount of alpha-emitting substance. The alpha particles emitted keep the air in the fire alarms slightly ionized and any changes in the level of ionization caused by smoke in a fire can be detected and the alarm is set off.

4. *Medical treatment* Radioactive cobalt, Co-60, decays with the emission of beta particles and high energy gamma rays. When properly shielded, the gamma rays can be brought to bear on deep cancerous growths in a cancer patient. The radiation kills the cell of the malignant tumour in the patient. Machines built for this purposes, known as gammatrons are very useful in radiotherapy.

5. *Archaeological dating* Radioactive carbon-14 is present in small amounts in the atmosphere. Living plants absorb carbon dioxide and therefore become slightly radioactive. This enables the level of radioactivity of plants to be monitored.

When a tree dies, the radioactive carbon present inside it will begin to decay. Since the half-life of carbon-14 is nearly 5500 years the age of a dead tree can be found by comparing the activity of the carbon-14 in the dead tree and a living tree.

The activity of the carbon-14 of a living tree stays fairly constant as the carbon-14 is being replenished while the carbon-14 in the dead tree is not replenished. Therefore, by measuring the activity of carbon-14 in an ancient relic, scientists can calculate its age.

#### **7.14 describe the dangers of ionising radiations, including:**

- Radiation can cause mutations in living organisms
- Radiation can damage cells and tissue
- The problems arising in the disposal of radioactive waste

and describe how the associated risks can be reduced.

*Hazard of radiation* Overexposure to radioactive radiation may result in radiation burns. These will lead to sores and blisters which may take a long time to heal. Extreme overexposure can lead to radiation sickness, and ultimately death. Radioactive radiation can also lead to delayed conditions such as eye cataracts or leukemia, which may only appear many years later.

Ionizing radiation causes mutations in the genes which led to offspring bearing physiological and other abnormalities. They are health hazards to people, livestock and plants.

*Precautions against radiation hazards* To prevent overexposure to radiation or any accidents, following precautions need to be taken:

1. Workers working with gamma radiation must wear film badges or pocket dosimeter in order to keep track of the accumulated dosage they are exposed to over given period time.



2. Always keep radioactive sources in lead-lined boxes. The wall of the storage rooms of nuclear laboratories are to be built with lead bricks that are 1m thick. The outside of the room must be labeled "Radioactive Material"
3. The radiation symbol must be displayed whenever an experiment with a radioactive source is conducted.
4. If possible, persons doing radiation experiments should use special, protective clothing such as lead-lined suits as well as wear lead-lined gloves. Tweezers must be used to pick up strong sources. After completion of the day's work, the contaminated clothing must be changed.
5. Food and drinks are strictly prohibited when a person is doing a radioactivity experiment. Otherwise, radioactive dust can be taken into the body together with food.
6. The nuclear process in a reactor produces a variety of different types of radioactive material. Some have relatively short half-lives and decay rapidly. These soon become safe to handle and do not present problems of long-term storage. Other materials have extremely long half - lives. These will continue to produce dangerous levels of ionising radiation for thousands of years. These waste products present a serious problem for long-term storage. They are usually sealed in containers that are then buried deep underground. The sites of underground storage have to be carefully selected. The rock must be impermeable to water and the geology of the site must be stable - storing waste in earthquake zones or area of volcanic activity would not be sensible.

### **(c) Fission and Fusion**

## **Section 8: Astrophysics**

[[toc]]

### **(a) Units**

- Kilogram (kg),
- Metre (m),
- Metre/second (m/s),
- Metre/second squared (ms<sup>2</sup>)
- Newton (N)
- Second (s),
- Newton/Kilogram (N/kg)

### **(b) Motion in the universe**

- A universe is a collection of billions of galaxies
- A galaxy is a collection of billions of solar systems
- A solar system contains stars and planets
- Gravity is a force that pulls all objects close to the surface of the planet towards the planet. The force of gravity depends on the inner core of the planet and since this varies from planet to planet, the gravity at each planet varies. Compared to Earth, the Moon has a weaker gravity whereas Jupiter has a much larger gravity.
- Gravity is responsible for keeping the moon, the planets, satellites, and comets in orbit.
- Planets orbit in a circular shape around a star as shown in figure 1
- Comets orbit in an ellipse shape around a star. The speed of the comet increases as it becomes closer to the star. This is shown in figure 2
- Moons orbit planets as shown in figure 3.

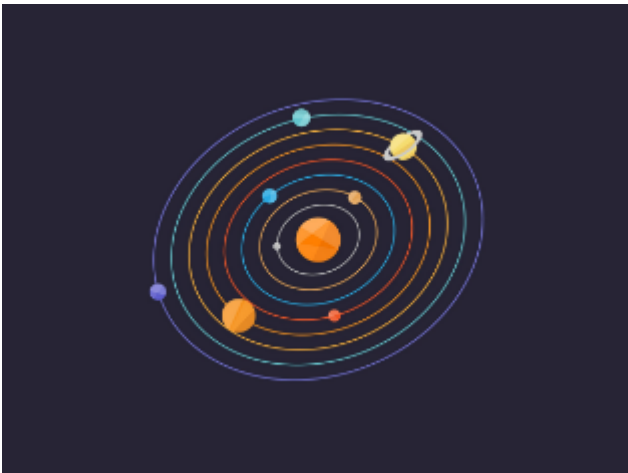

Figure 1

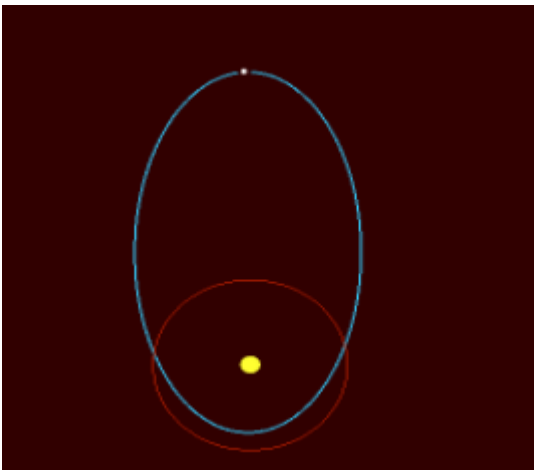

Figure 2



Figure 3

Important equation to keep in mind!!!

$$\text{orbital speed} = \frac{2 \times \pi \times \text{orbital radius}}{\text{time period}}$$

$$v = \frac{2 \times \pi \times r}{T}$$

## (c) Stellar evolution

### What is the milky way?

The name of our galaxy is the milky way. It is a spiral galaxy.

### What is Galaxy?

Due to high gravitational force many stars form a group called a galaxy.

### How does the colour of stars tell us about their temperature?

- A very hot star emits more blue in its spectrum and therefore looks blue,
- A medium star like our sun looks yellow and,
- A cooler star appears red.

### What are the two factors that brightness of a star depends on?

- The two factors are:
- The distance between a star and the earth.
- The luminosity of the star.

### Describe the birth of a star.

Dust and gas particles are drawn together by gravitational forces. Compression of these particles causes an increase in temperature. Due to high temperature nuclear reactions begin. When nuclear fusion reaction starts, hydrogen nuclei join together to make a large nuclei. Huge amount of energy is released in the form of heat and light, therefore, it forms a hot ball of gas which is a young star. Unused material around the young star begins to group together to form planets, moons and comets which orbit the star.

### What happens to a star after the stable period?

- The star expands and becomes cool.
- It forms a red giant.
- The star collapses and the temperature is increased.
- Due to high temperature, the star changes colour.
- It emits more blue and white light.
- It changes into a white dwarf star.
- The white dwarf star cools and forms a black dwarf star.

### What is a supernova?

A star which is much larger than our sun expands into a large, red supergiant. After the stable period, then it contracts and becomes unstable. It explodes throwing dust and gas into space to form a new stellar nebula. This exploding star is called supernova.

#### **What is a neutron star?**

After the explosion to form supernova of a large red giant star, remaining dust and gas particles form a very dense star called neutron star.

#### **What is black hole?**

If the neutron star has a mass of five times greater than the sun or more, it collapses further to become a black hole.

### **(d) Cosmology**

#### **What is the doppler effect?**

- The apparent change in frequency is called the doppler effect.
- The doppler effect is the property of all waves.
- Due to doppler effect, the frequency and wavelength of light wave changes and then the light wave changes its colour in its spectrum.

#### **Define redshift and blueshift.**

- Redshift indicates that the source of the light wave is moving away from the observer. Almost all the galaxies emit light with redshift.
- The further away a galaxy is, the greater the redshift and therefore the faster it is moving away from us.
- The frequency of light decreases and wavelength increases.

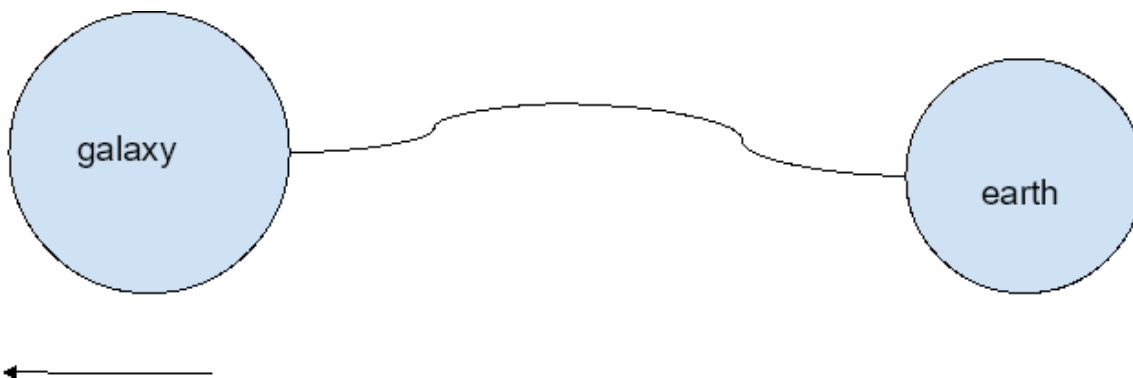

Fig: Redshift

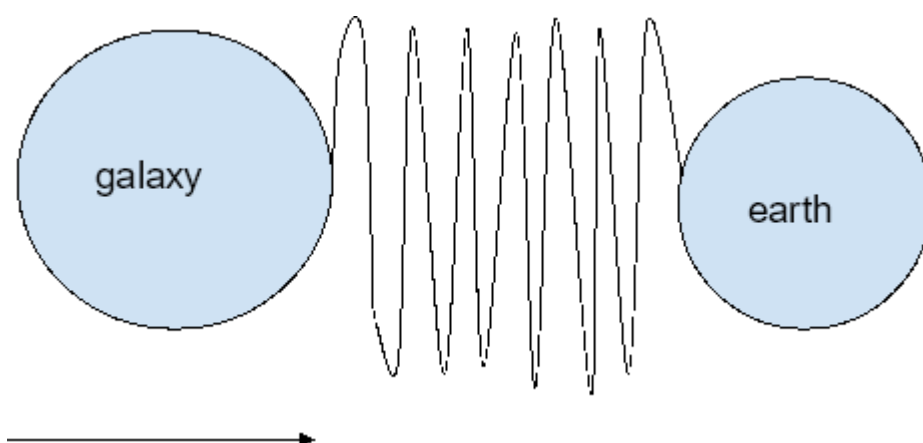

Fig: blueshift

- Blue shift indicates that the source of light wave is moving towards the observer.
- The frequency of light increases and wavelength decreases.

### What is Big Bang Theory?

Scientists believe that the universe is expanding with time. In the past, all the matter in the universe was in one place just before an explosion. This theory is called the Big Bang Theory.

### Write down the doppler equation

$$\frac{\Delta\lambda}{\lambda_0} = \frac{v}{c}$$

$\Delta\lambda = \text{wavelength shift}$

$\lambda_0 = \text{wavelength of source not moving}$

$v = \text{velocity of source} - \text{line of site}$

$c = \text{speed of light}$

### Define Cosmic Microwave Background (CMB) radiation.

According to the Big Bang Theory, the universe is expanding with time and it releases energy. This energy is released in the form of wave. The wavelength of this wave is longer than before. The wavelength is in the microwave part of the electromagnetic spectrum. This microwave radiation is detected in all directions in the universe. This is known as Cosmic Microwave Background radiation.

## title: IGCSE Physics Revision Note PDF

[Download PDF](#)

## Appendix 1: Electrical circuit symbols

Description	Symbol	Description	Symbol
Conductors crossing with no connection		heater	
Junction of conductors		thermistor	
Open switch		light-dependent resistor (LDR)	
Closed switch		relay	
Open push switch		diode	
Closed push switch		light-emitting diode (LED)	
Cell		lamp	
Battery of cells		loudspeaker	
Power supply		microphone	
Transformer		electric bell	
Ammeter		earth or ground	
Milliammeter		motor	
Voltmeter		generator	
Fixed resistor		fuse/circuit breaker	
Variable resistor			

## Appendix 2: Physical units

<b>Quantity</b>	<b>Units</b>
<b>Speed</b>	m/s
<b>Velocity</b>	m/s
<b>Acceleration</b>	$m/s^2$
<b>Distance</b>	m
<b>Time</b>	s
<b>Force</b>	N
<b>Mass</b>	kg
<b>Weight</b>	N
<b>Momentum</b>	kg m/s
<b>Moment</b>	Nm
<b>Power</b>	W
<b>Current</b>	A
<b>Voltage</b>	v
<b>Resistance</b>	$\Omega$
<b>Energy</b>	J
<b>Charge</b>	C
<b>Frequency</b>	Hz
<b>Time period</b>	s
<b>Wave speed</b>	m/s
<b>Wavelength</b>	m
<b>Critical angle</b>	°
<b>Work done</b>	J
<b>Gravitational field strength</b>	N
<b>Density</b>	$Kg/m^3$
<b>Volume</b>	$m^3$
<b>Pressure</b>	Pa
<b>Area</b>	$m^2$
<b>Height</b>	m

<b>Temperature</b>	°C
<b>Radioactivity</b>	Bq

## Appendix 3: Prefixes

Prefix	Symbol	Multiple
pico	P	$10^{-12}$
nano	n	$10^{-9}$
micro	$\mu$	$10^{-6}$
milli	m	$10^{-3}$
centi	c	$10^{-2}$
deci	d	$10^{-1}$
kilo	k	$10^3$
mega	M	$10^6$
giga	G	$10^9$
tera	T	$10^{12}$

## Appendix 4: Formulae and Relationships

1. Speed = distance / time taken
2. Velocity = displacement / time taken
3. Average velocity = (initial velocity + final velocity) / 2
4. Weight = mass \* gravitational field strength
5. Momentum = mass \* velocity
6. Force = (mv - mu) / t
7. increase in momentum = force \* time
8. Moment = Force \* distance
9. Sum of clockwise moments = sum of anticlockwise moments
10. Power = Current \* Voltage
11. Energy = power \* time
12. Voltage = current \* resistance
13. Charge = current \* time
14. frequency = 1 / Time period
15. Speed = frequency \* wavelength
16. refractive index =  $\sin i / \sin r$
17.  $\sin c = 1 / n$
18. efficiency = (useful energy output from the system / total energy input to the system) \* 100%
19. work done = force \* distance
20. Gravitational potential energy = mass \* gravitational field strength \* height



21. Kinetic energy =  $\frac{1}{2} mv^2$
22. Power = Work done / time taken
23. Density = mass / Volume
24. Pressure = Force / Area
25. Pressure difference = height  $\times$  pressure  $\times$  gravitational field strength
26.  $P_1 \cdot V_1 = P_2 \cdot V_2$
27. Temperature in K = temperature in  $^{\circ}\text{C} + 273$
28.  $P / T = P_2 / T_2$
29.  $V_p / V_s = n_p / n_s$
30. Power input = Power out
31. Voltage in primary current  $\times$  Current in primary current = Voltage in secondary current  $\times$  Current in secondary current
32. Orbital Speed =  $2\pi r / T$
33.  $S = ut + \frac{1}{2} at^2$

PDF auto-generated from [Shawon Notes](#). If you found it useful, please consider contributing to the project in [Github](#).